

## MODEL NO. 60005 Universal Deck Support

### PARTS LIST

DESCRIPTION	No. REQ'D	PART NUMBER
Universal Deck Center Support	1	305825
<b>Hardware Complete</b>	1	305905
3/8" x 3/4" P.B.H.C.S. w/ Patch	16	812052*
3/8" Lockwasher	17	817334*
3/8" Flat Washer	1	817410*
3/8" (1 1/4" O.D.) Flat Washer	16	817424*
3/8" Hex Nut	1	804053*
3/8" T-Nut	16	804556*

**Unless Otherwise Specified, All Units of Measure are Each  
\*Included in Hardware**

**Warning: Small parts and hardware items may present a potential choking hazard. Promptly remove all unused parts from play area.**

#### SPECIFICATIONS:

Universal deck support is a one piece weld assembly fabricated from 2 3/8" O.D. galvanized tubing, 1/4" thick deck support plate and 3/8" thick round filler plate. Support receives a baked on powder coated finish.

All hardware is stainless steel.

#### INSTALLATION INSTRUCTIONS:

Note: Universal Deck Support is required for installing different deck configurations at the same height.

1. Locate flush mounted decks to receive deck support. Refer to overall top view. Support provided is for a 8' deck height, for lower deck heights support will require cutting to a length equal to the deck height needed plus 30". For example, a 4' deck height will need the support cut to a length of 78".
2. Dig footing for Support as shown in footing detail.
2. Attach deck support to one of the deck bolts using 3/8" Flatwasher (817410), 3/8" Lockwasher (817334) and 3/8" Hex Nut (804053). Refer to detail "A". Cut off all unused deck bolts and excess threads from deck bolt used for attachment to prevent protrusion.
3. Attach decks together using 3/8" x 3/4" P.B.H.C.S (812052), 3/8" Lockwasher (817334), 3/8" (1 1/4" O.D.) Flatwashers (817424) and 3/8" T-Nut (804556). Refer to detail "B".

#### MAINTENANCE PROCEDURE:

Periodically check hardware for tightness, and tighten as necessary. Always check all parts for breakage or wear, and immediately put equipment out of service until any faulty parts found are repaired or replaced. Check for rust or paint loss and touch-up if necessary with paint. Check welded areas and verify integrity. Check Plastisol-coating for bare spots and touch-up with Plastisol if necessary. Clear any trapped debris from deck perforations. Check periodically resilient surfacing for appropriate depth and remove extraneous materials that could cause injury, infection, or disease. Maintain detailed installation, inspection, maintenance, and repair records for each public-use playground equipment.

## MODEL NO. 60005 Universal Deck Support

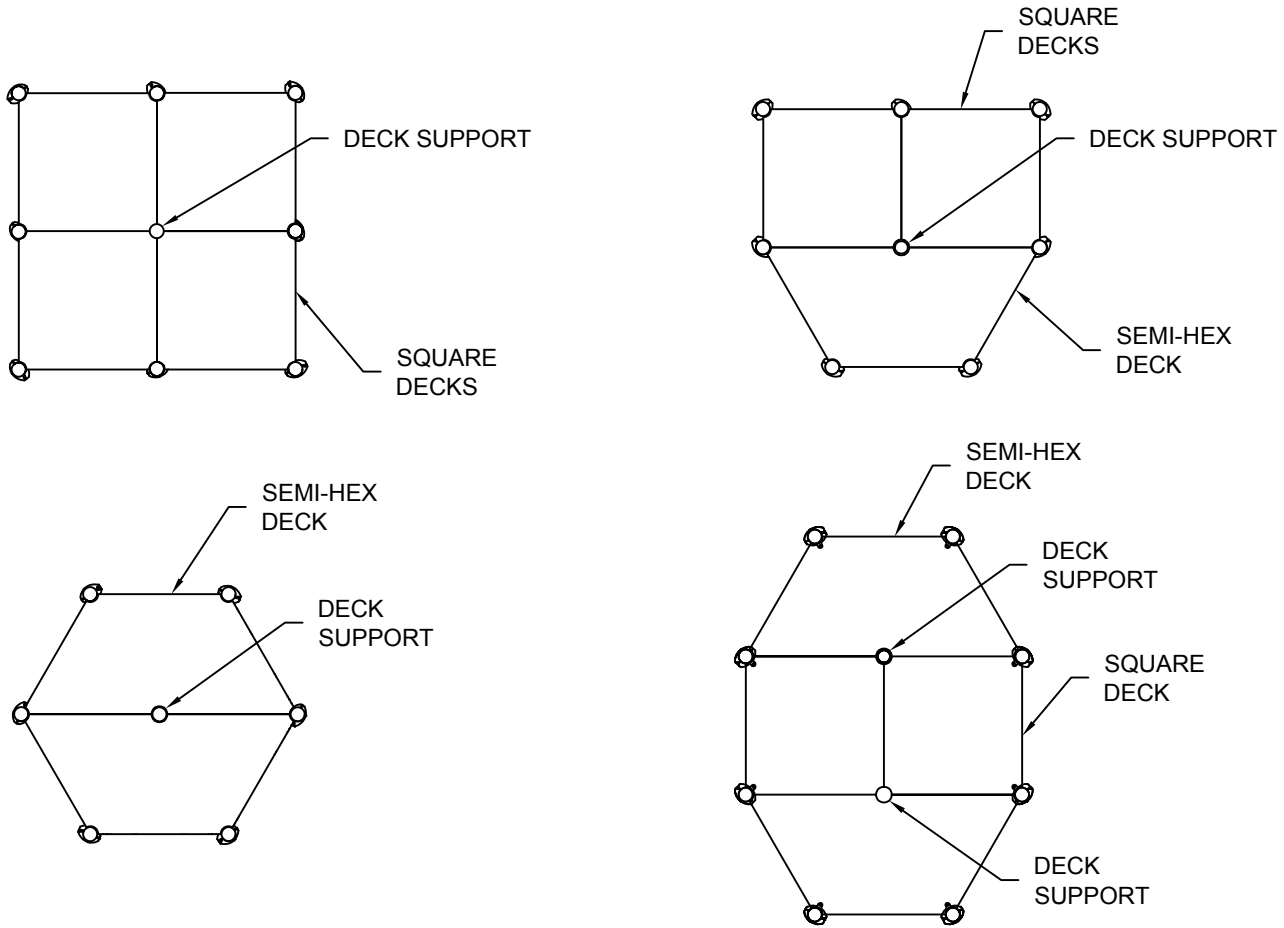

### DECK CONFIGURATIONS

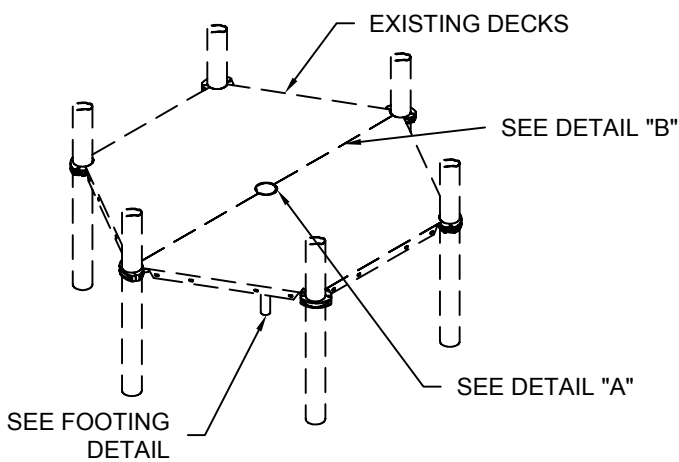

### FINISHED ASSEMBLY

TWO SEMI-HEX DECKS SHOWN  
OTHERS SIMILAR

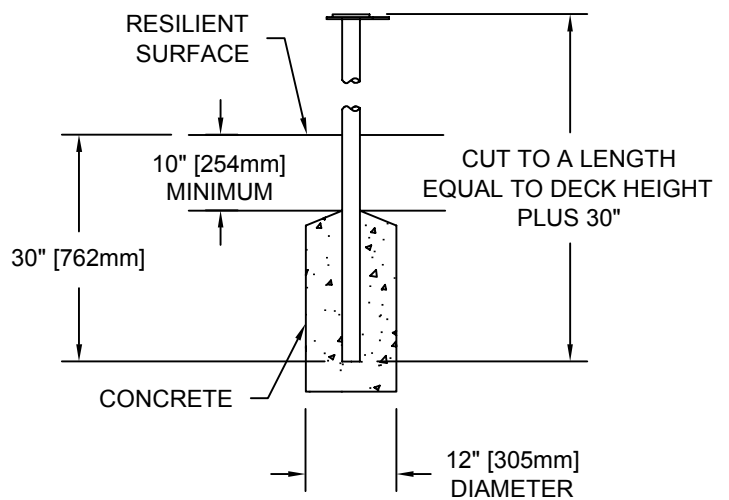

### FOOTING DETAIL

## MODEL NO. 60005 Universal Deck Support

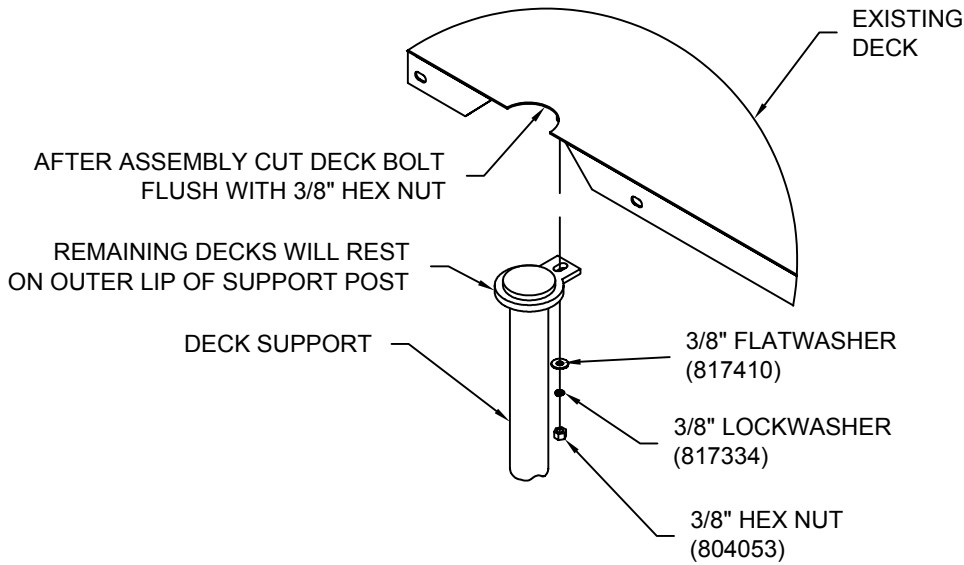

DETAIL "A"

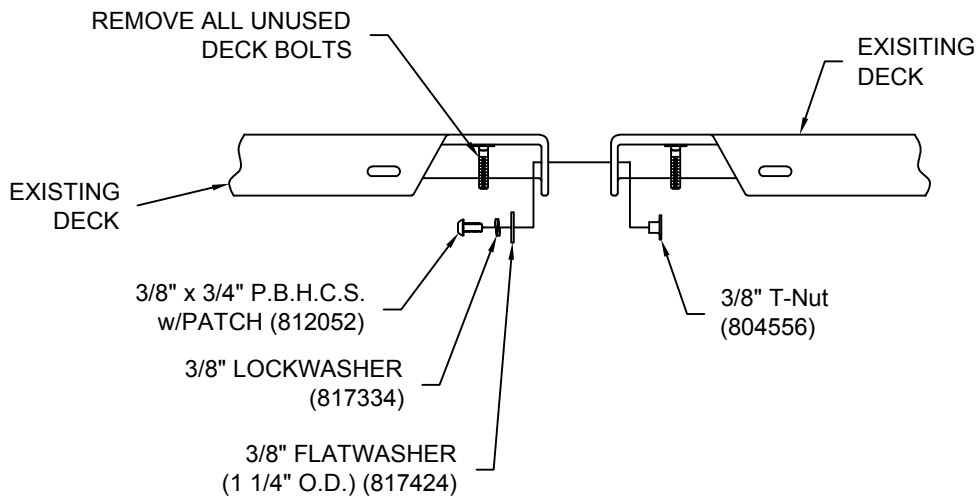

DETAIL "B"