

MODEL NO. 60013 Supermax Single Metal Button Step

PARTS LIST

DESCRIPTION	No. REQ'D	PART NUMBER
Plastisol-coated Button Step	1	300549
Button Step Center Support Post-48"	1	305612
<i>Hardware Complete</i>	1	302100
3/8" Flat Washer	4	817410*
3/8" x 1" P.B.H.C.S. w/Patch	4	812050*
3/8" Lock Nut	4	804353*
3/8" Flat Washer (1 1/4" O.D.)	4	817424*

Unless Otherwise Specified, All Units of Measure are Each
*Included in Hardware

Warning: Small parts and hardware items may present a potential choking hazard. Promptly remove all unused parts from play area. Any bolt end protruding more than two full threads beyond the face of the nut causes risk of clothing entanglement. Promptly cut-off flush, file smooth, and treat to prevent corrosion.

Note: Peen Tee-Nuts and Flatwashers to match radius of pipe after assembly is complete.

Note: Loctite (supplied by others) should be used on any non-patch hardware.

SPECIFICATIONS:

Button Step is fabricated from pre-punched steel sheet 11-gauge thickness with steel flat support bars welded underneath to increase strength. After welding, the entire step is Plastisol-coated with a thickness of 50 to 80 mils on top wear surface. Average perforation size is 3/16" diameter after coating. Center Support Post consists of 3/16" H.R. steel that is steel welded to 3-1/2" O.D. steel tubing, and receives a baked-on polyester powder-coated finish after fabrication.

Primary hardware is stainless steel.

Weight: 30 lb. / 13.6 kg

INSTALLATION INSTRUCTIONS:

NOTE: Button Step can be used alone, or in groups. If used in groups, it is recommended that this step be positioned maximum 24" from Center-to-Center of footings and maximum 6" difference in height between steps. If being used with a deck 24" in height or more, U-Handles must be purchased separately.

1. Dig footings as shown in the Assembly Diagram. Refer to your overhead drawing for location.
2. Attach Button Step to Center Support Post using 3/8" x 1" P.B.H.C.S. w/Patch with 3/8" Flat Washers and 3/8" Lock Nuts with 3/8" Flat Washers (1 1/4" O.D.) as shown in Assembly Diagram.
3. Level and brace step into position and pour concrete footing within 4" to the top and taper away from post to allow water drainage. Allow to cure at least 48 hours before use.
4. When the structure is finished and satisfactory, eliminate sharp points and sharp edges (burring) on installed hardware like bolts, nuts, etc. Install resilient surfacing material within the *use zone* of play structure in accordance with ASTM specifications F1292 appropriate for the fall height of each structure. Refer to the *Safety Guidelines*.

MAINTENANCE PROCEDURE:

Periodically check hardware for tightness, and tighten as necessary. Always check all parts for breakage or wear, and immediately put equipment out of service until any faulty parts found are repaired or replaced. Check for rust or paint loss and touch-up if necessary with paint. Check welded areas and verify integrity. Check Plastisol-coating for bare spots and touch-up with Plastisol if necessary. Clear any trapped debris from deck perforations. Check periodically resilient surfacing for appropriate depth and remove extraneous materials that could cause injury, infection, or disease. Maintain detailed installation, inspection, maintenance, and repair records for each public-use playground equipment.

MODEL NO. 60013 Supermax Single Metal Button Step

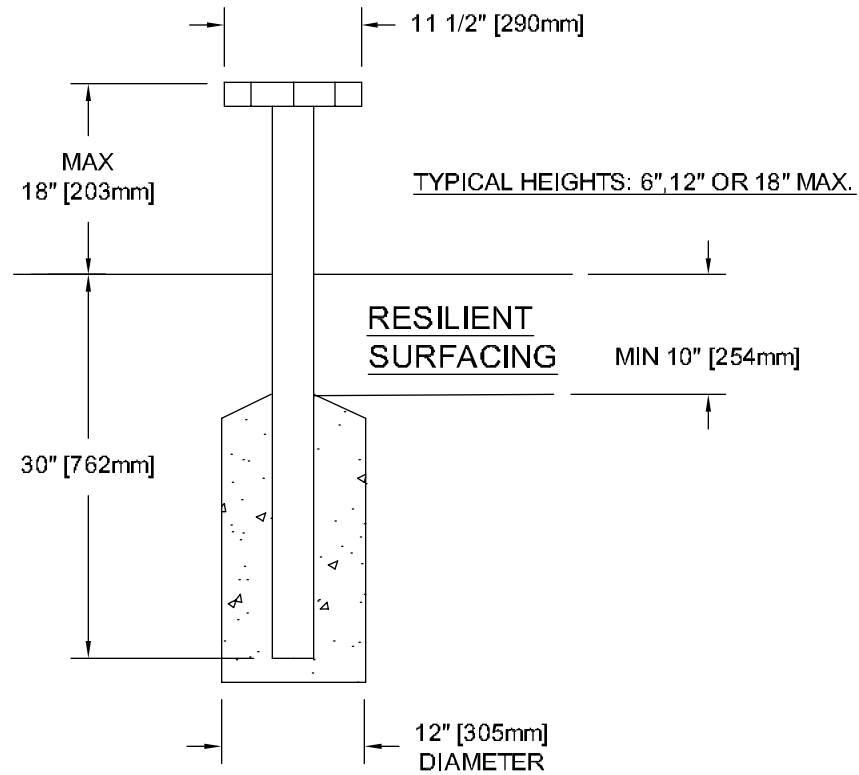
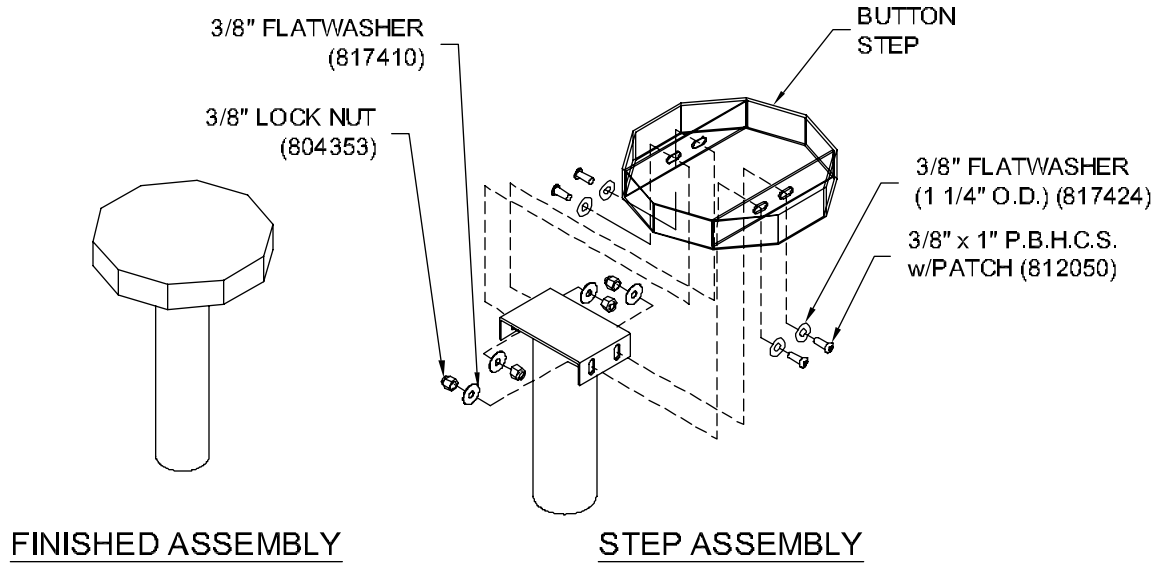

ELEVATION VIEW