

MODEL NO. 60039 Aluminum Arch MODEL NO. G60039 Galvanized Arch

PARTS LIST

	DESCRIPTION	No.REQ'D		PART NUMBER
		60039	G60039	
1	Arch Ass'y (Aluminum)	1	0	300823
1	Arch Ass'y (Galvanized)	0	1	300820
	Hardware Complete	1	1	302298
	Drive Rivet	4	4	168449*

*Unless Otherwise Specified, All Units of Measure are Each
* Included in Hardware*

Warning: Small parts and hardware items may present a potential choking hazard. Promptly remove all unused parts from play area.

ALUMINUM SPECIFICATIONS:

Arch is 5" O.D. x 144", 0.125" wall thickness 6005-T5 extruded seamless Aluminum tubing. Tensile strength is 38,000 psi, and yield strength is 35,000 psi. Entire arch is polyester powder-coated after fabrication.

Weight: 33 lb. / 15 kg.

GALVANIZED SPECIFICATIONS:

Post is 5" O.D. 11-gauge galvanized steel tubing with a baked-on polyester powder-coated finish.

Weight: 70 lb. / 31.8 kg.

INSTALLATION INSTRUCTIONS:

1. Refer to the main overhead drawing to locate posts to receive arches.
2. Insert arch into appropriate uprights. Drill 1/4" diameter holes to receive drive rivets
See assembly detail.

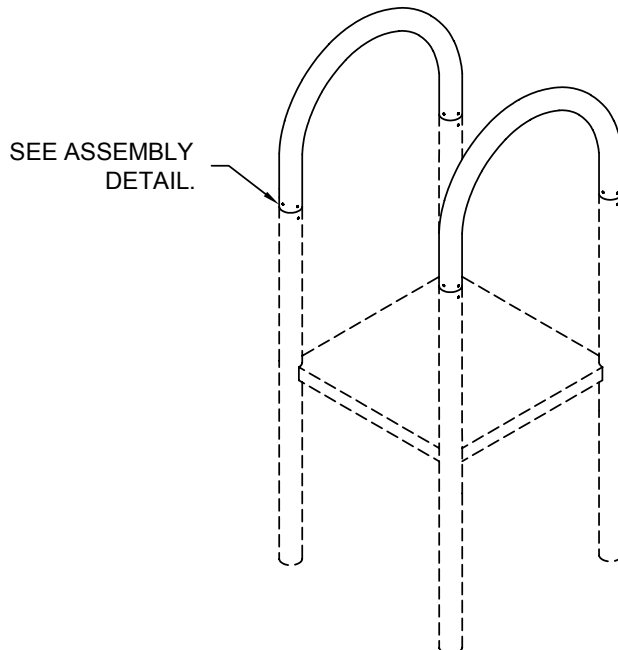

FINISHED ASSEMBLY

park a PlayCore company
structures®

MODEL NO. 60039 Aluminum Arch
MODEL NO. G60039 Galvanized Arch

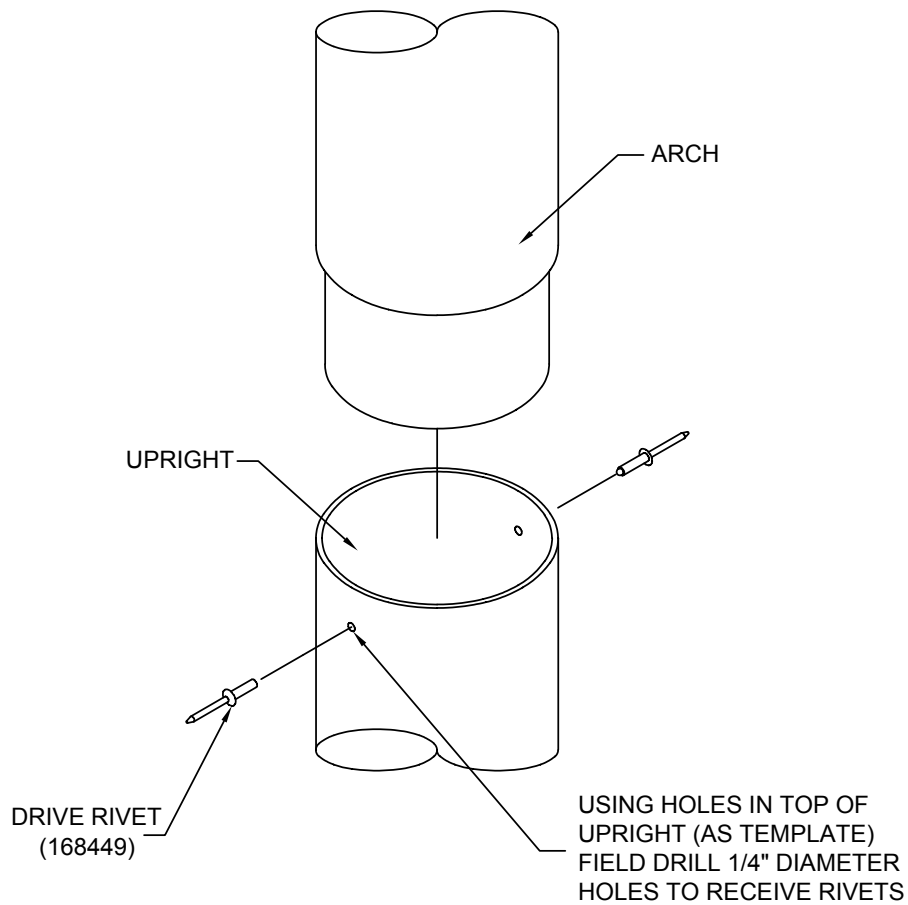

ASSEMBLY DETAIL