

MODEL NO.60046 Playwheel for 5" O.D. Post

PARTS LIST

DESCRIPTION	No. REQ'D	PART NUMBER
Playwheel	1	301792
Hardware Complete	1	302321
5" O.D. 1/2 Clamp	2	301001*
1/4" x 3/4" Drive Rivet	2	168449*
3/8" Flat Washer	8	817410*
3/8" Lock Nut	4	804353*
3/8" x 1 1/2" P.B.H.C.S. w/ Patch	4	812053*

**Unless Otherwise Specified, All Units of Measure are Each
*Included in Hardware**

Warning: Small parts and hardware items may present a potential choking hazard. Promptly remove all unused parts from play area.

SPECIFICATIONS:

Half-Clamps are cast from a 356 high-strength aluminum alloy with a baked-on polyester powder-coated finish. Playwheel is an all-welded wheel free-turning. A grease impregnated bronze bushing is pressed into the shaft to provide smooth turning. Bracket is formed from 3/16" thick steel clamp. The entire Playwheel receives a baked-on polyester powder-coated finish.

All hardware is stainless steel.

Weight: 8 lb. / 3.6 kg

INSTALLATION INSTRUCTIONS:

1. Attach Playwheel to a pre-existing Upright Post using Half-Clamp, 3/8" x 1-1/2" P.B.H.C.S. with Patch with 3/8" Flat Washer and 3/8" Lock Nut with 3/8" Flat Washers as shown in the assembly diagram.
2. When the assembly is finished and satisfactory, install Drive Rivets in half clamps to ensure clamps cannot slide down posts. Also eliminate sharp points and sharp edges (burring) on installed hardware like bolts, nuts, etc. See Pipe Clamp sub-assembly sheet. It is very important that all Drive Rivets be installed before allowing use of the equipment, as clamps are not designed to support substantial weight without them. Install resilient surfacing material within the use zone of play structure in accordance with ASTM specifications F1292 appropriate for the fall height of each structure. Refer to the Safety Guidelines.

MAINTENANCE PROCEDURE:

Periodically check hardware for tightness, and tighten as necessary. Always check all parts for breakage or wear, and immediately put equipment out of service until any faulty parts found are repaired or replaced. Also Check all metal parts for rust, paint loss and touch-up if necessary with paint. Check for welded areas and verify integrity. Check periodically resilient surfacing for appropriate depth and remove extraneous materials that could cause injury, infection, or disease. Maintain detailed installation, inspection, maintenance, and repair records for each public-use playground equipment.

MODEL NO.60046 Playwheel for 5" O.D. Post

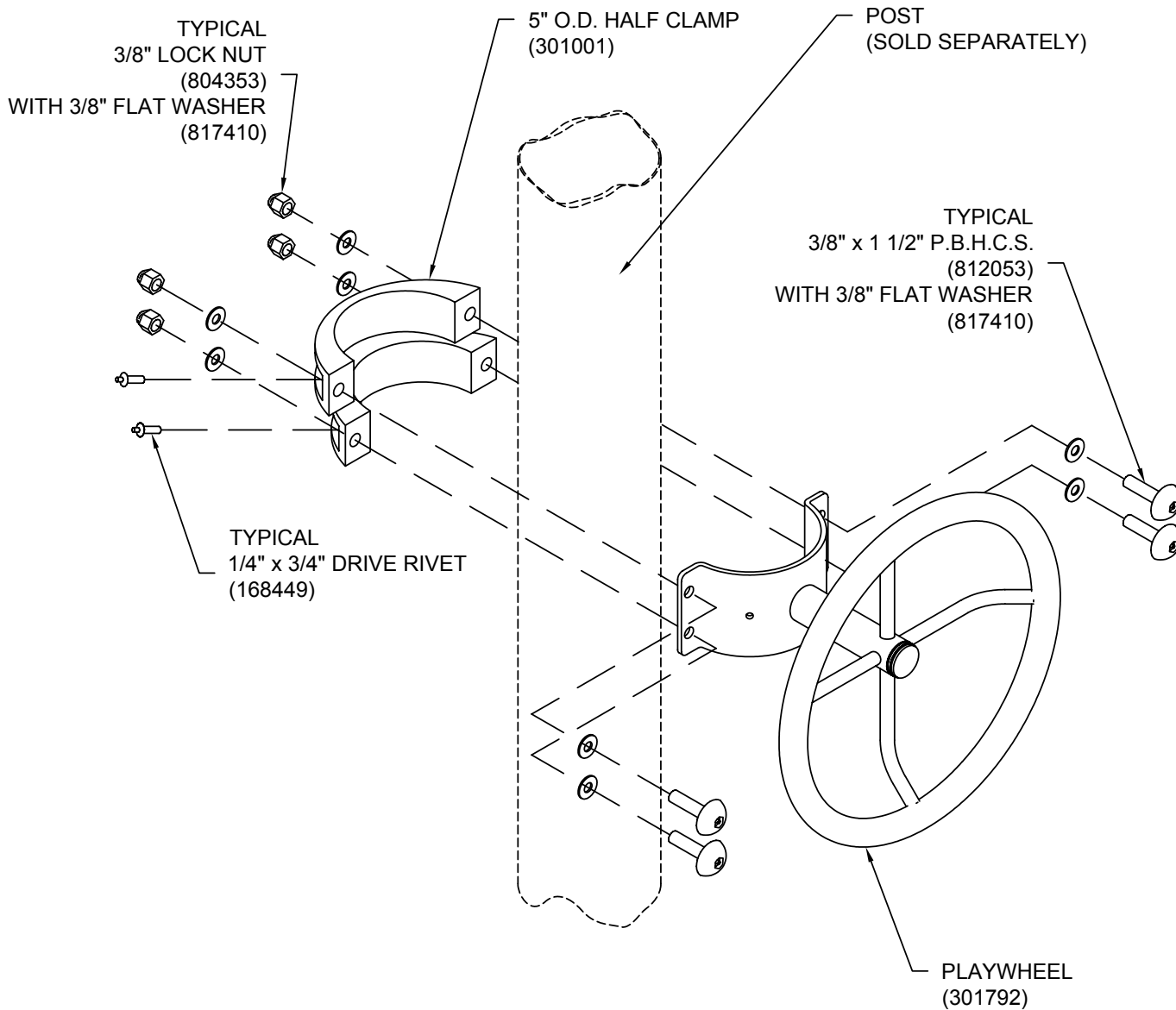

FINISHED ASSEMBLY