

MODEL NO. 60051 BALCONY DECK w/PLAYWHEEL

PARTS LIST

DESCRIPTION	No. REQ'D	PART NUMBER
Plastisol-coated Balcony Deck	1	300531
Balcony Deck Pipe Wall	1	305513
Steering Wheel Assembly	1	163235
Hardware Complete	1	302367
5" O.D. Deck Clamp	2	301989*
1/4" x 3/4" Drive Rivet	2	168449*
3/8" Barrel Nut	4	804804*
3/8" Flat Washer	7	817410*
3/8" Heavy Hex Nut	2	804200*
3/8" x 3/4" P.B.H.C.S. w/Patch	2	812052*
3/8" x 1 1/2" P.B.H.C.S. w/Patch	2	812053*
3/8" x 1 1/4" P.B.H.C.S. w/Patch	7	812051*
3/8" x 1 3/4" P.B.H.C.S. w/Patch	2	812054*
3/8" Lock Nut	7	804353*
3/8" Flat Washer (1 1/4" O.D.)	11	817424*
3/8" Acorn Nut	2	804002*
3/8" Lockwasher	2	817334*

*Unless Otherwise Specified, All Units of Measure are Each
* Included in Hardware*

Warning: Small parts and hardware items may present a potential choking hazard. Promptly remove all unused parts from play area.

SPECIFICATIONS:

Clamps are cast from a 356 high-strength aluminum alloy with a baked-on polyester powder-coated finished.

Deck is fabricated from pre-punched steel sheet 12-gauge thick with steel flat support bars welded underneath to increase strength. After welding, the entire platform is Plastisol-coated using brown PVC with a thickness of 50 to 80 mils on top wear surface. Average perforation size is 0.35" diameter after coating.

Balcony Pipe Wall is and all-stainless steel welded assembly using 1-5/16" O.D. 14-gauge galvanized steel tubing. The entire assembly is polyester powder-coated after fabrication.

The steering wheel is molded of a durable proprietary plastic and shall withstand an impact of over 250 foot-pounds. A grease impregnated bronze bushing is pressed into the shaft to provide smooth turning. The steering wheel mounting bracket is formed of 3/16" thick steel and has a powder coat finish. All hardware is stainless steel.

Weight: 99 lb. / 45 kg.

INSTALLATION INSTRUCTIONS:

NOTE: A Square, Triangle, or Hex Deck must be already installed and in place on the main structure prior to commencing installation of the Balcony Deck. Such existing deck must be oriented so that its flange with the welded underside supports coincides with the attachment of the Balcony Deck for maximum strength and rigidity.

- Place Balcony Deck on a flat surface. If necessary, using a 7/16" drill bit, ream out excess plastisol coating from the (4) holes located on the flange, as well as the (4) holes located on the flange of the existing deck for attachment. Be careful not to expose steel frame.
- Position the Balcony Deck against the flange of the existing deck and fasten the flanges together using 3/8" x 1-1/4" P.B.H.C.S. with 3/8" Wide Flat (Fender) Washers and 3/8" Lock Nuts as shown in the assembly diagram.
- Attach Balcony Deck Pipe Wall to Posts using Deck Clamps, 3/8" x 1-3/4" P.B.H.C.S. with 3/8" Flat Washers and 3/8" Barrel Nuts as shown. Position so that slots on bottom tabs match Balcony flange holes while balcony is held level. Only slightly tighten top two Deck Clamps to the Upright Posts. Fasten bottom tabs of Balcony Pipe Wall to flange of Balcony Deck using 3/8" x 1-1/4" P.B.H.C.S. with 3/8" Flat and Wide Flat (Fender) Washers and 3/8" Lock Nuts as shown in the assembly diagram.

MODEL NO. 60051 BALCONY DECK w/PLAYWHEEL

4. Attach Steering Wheel Assembly to the Pipe Wall using two each 3/8" x 3/4" P.B.H.C.S., 3/8" Flatwasher, 3/8" Lockwasher and 3/8" Acorn Nut as shown in the assembly diagram.
5. When the structure is finished and satisfactory, install Drive Rivets in all clamps to ensure clamps cannot slide down posts. See a Deck Clamp subassembly sheet. It is very important that all Drive Rivets be installed prior to allowing use of the equipment, as clamps are not designed to support substantial weight without them. Eliminate sharp points and sharp edges (burring) on installed hardware like bolts, nuts, etc.
6. Install resilient surfacing material within the use zone of play structure, in accordance with ASTM specifications F1292 appropriate for the fall height of each structure. Refer to the Safety Guidelines.

MAINTENANCE PROCEDURE:

Periodically check hardware for tightness, and tighten as necessary. Always check all parts for breakage or wear, and immediately put equipment out of service until any faulty parts found are repaired or replaced. Check for rust, paint loss and touch-up if necessary with paint. Check Plastisol-coating for bare spots and touch-up with Plastisol if necessary. Clear any trapped debris from deck perforations. Check periodically resilient surfacing for appropriate depth and remove extraneous materials that could cause injury, infection, or disease. Maintain detailed installation, inspection, maintenance, and repair records for each public-use playground equipment.

MODEL NO. 60051 BALCONY DECK w/PLAYWHEEL

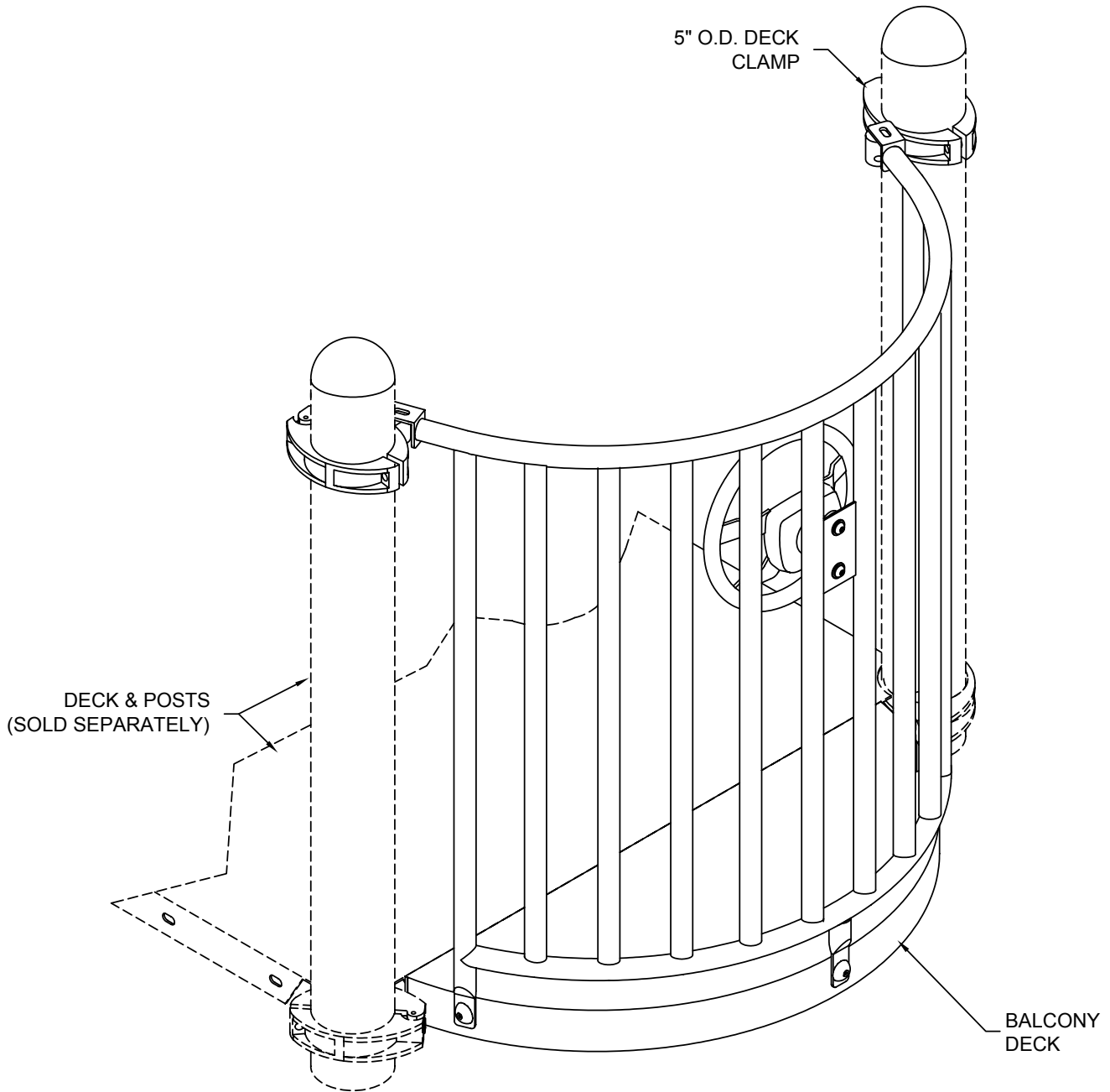

FINISHED ASSEMBLY

MODEL NO. 60051 BALCONY DECK w/PLAYWHEEL

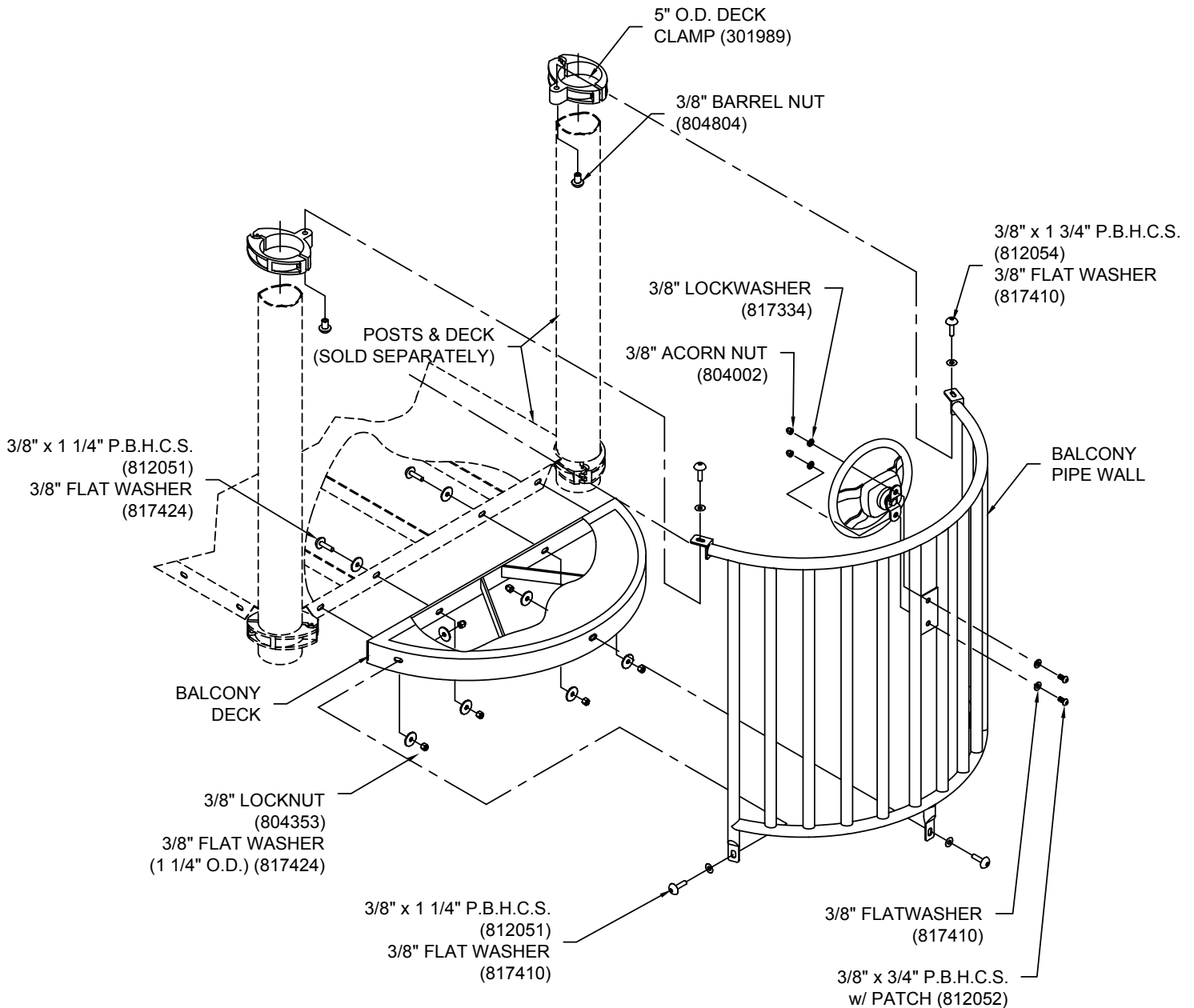

BALCONY DECK ASSEMBLY