

MODEL NO. 60057 Semi-Hex Deck

PARTS LIST

DESCRIPTION	No. REQ'D	PART NUMBER
Semi-Hex Platform (Pre-Punched)	1	300185
Hardware Complete	1	302410
5" O.D. Deck Clamp	5	301989*
1/4" x 3/4" Drive Rivet	5	168449*
3/8" Barrel Nut	5	804804*
3/8" Heavy Hex Nut	5	804200*
3/8" x 1 1/2" P.B.H.C.S.	5	812053*

**Unless Otherwise Specified, All Units of Measure are Each
*Included in Hardware**

Warning: Small parts and hardware items may present a potential choking hazard. Promptly remove all unused parts from play area. Any bolt end protruding more than two full threads beyond the face of the nut causes risk of clothing entanglement. Promptly cut-off flush, file smooth, and treat to prevent corrosion.

Note: Peen Tee-Nuts and Flatwashers to match radius of pipe after assembly is complete.

Note: Loctite (supplied by others) should be used on any non-patch hardware.

SPECIFICATIONS:

Clamps are cast from a 356 high-strength aluminum alloy with a baked on polyester powder-coated finish.

Semi-Hex Platform is fabricated from pre-punched 11-gauge steel sheet with built-in 3/8" x 1-3/4" bolts on each corner of the deck to be attached to a deck clamp. Each deck uses 1-1/2" wide by 11-gauge thick lower steel flat bar supports, which are welded to the deck to increase strength. After fabrication, entire deck is Plastisol coated to a minimum thickness of 1/8". Perforation size is 5/16" Diameter After coating.

Primary hardware is stainless steel.

Weight: 155 lb. / 70.5 kg

INSTALLATION INSTRUCTIONS:

- Place Upright Posts in dug holes at appropriate height per Upright Post installation instructions. Get the height required for the deck from the Plan View Diagram. Use a felt-tip marker to mark the top of the Deck Clamp on all posts.

HINT: If this is the first deck of the structure, locate and concrete one post only (preferably the most shared post, if this deck is part of a multi deck group), ensuring it is plumb and at the right height. After it has had a chance to set, place one corner of the deck against the post and mark the location of the adjacent post. Concrete the second post. Continue this procedure for all five posts while leaving the deck on the ground. The deck has been used as its own template, and the deck is now easily attached as its posts are already in place.

- Attach all five Deck Clamps with the boss pointing toward the center of the deck. Tighten each clamp slightly using 3/8" x 1-1/2" P.B.H.C.S. and 3/8" Heavy Hex Nuts.
- Place the deck so that each corner bolt fits on a clamp hole, and fasten using a 3/8" Barrel Nut at each corner. Do not tighten. Plumb and level posts and brace in position.
- Using a level, and holding one clamp as a constant, adjust the other four clamps so that the deck is completely level. At this point, if you have more decks to attach, lay each succeeding deck on the ground against the previous deck's two posts, and mark the missing footings to be dig. Continue attaching decks in this manner.
- When all decks are completed and correct, pour concrete footings within 4" to the top and taper away from support posts to allow water drainage. Allow curing at least 48 hours before use.

MODEL NO. 60057 Semi-Hex Deck

6. When the structure is finished and satisfactory, install Drive Rivets in all clamps to ensure clamps cannot slide down posts. See Deck Clamp subassembly sheets. **It is very important that all Drive Rivets be installed prior to allowing use of the equipment, as clamps are not designed to support substantial weight without them.**

Note: To cushion accidental falls by children, Park Structures strongly recommends that the area under and around the play structure must be covered with a resilient material, such as sand, mulch, etc., to a minimum depth of 10" for sand. Approved rubber safety matting can also be used. For details, please refer to your Safety Guidelines, provided within the assembly instruction packet.

MAINTENANCE PROCEDURE:

Periodically check hardware for tightness, and tighten as necessary. Always check all parts for breakage or wear, and immediately put equipment out of service until any faulty parts found are repaired or replaced. Check for rust or paint loss and touch-up if necessary with paint. Check welded areas and verify integrity. Check Plastisol-coating for bare spots and touch-up with Plastisol if necessary. Clear any trapped debris from deck perforations. Check periodically resilient surfacing for appropriate depth and remove extraneous materials that could cause injury, infection, or disease. Maintain detailed installation, inspection, maintenance, and repair records for each public-use playground equipment.

MODEL NO. 60057 Semi-Hex Deck

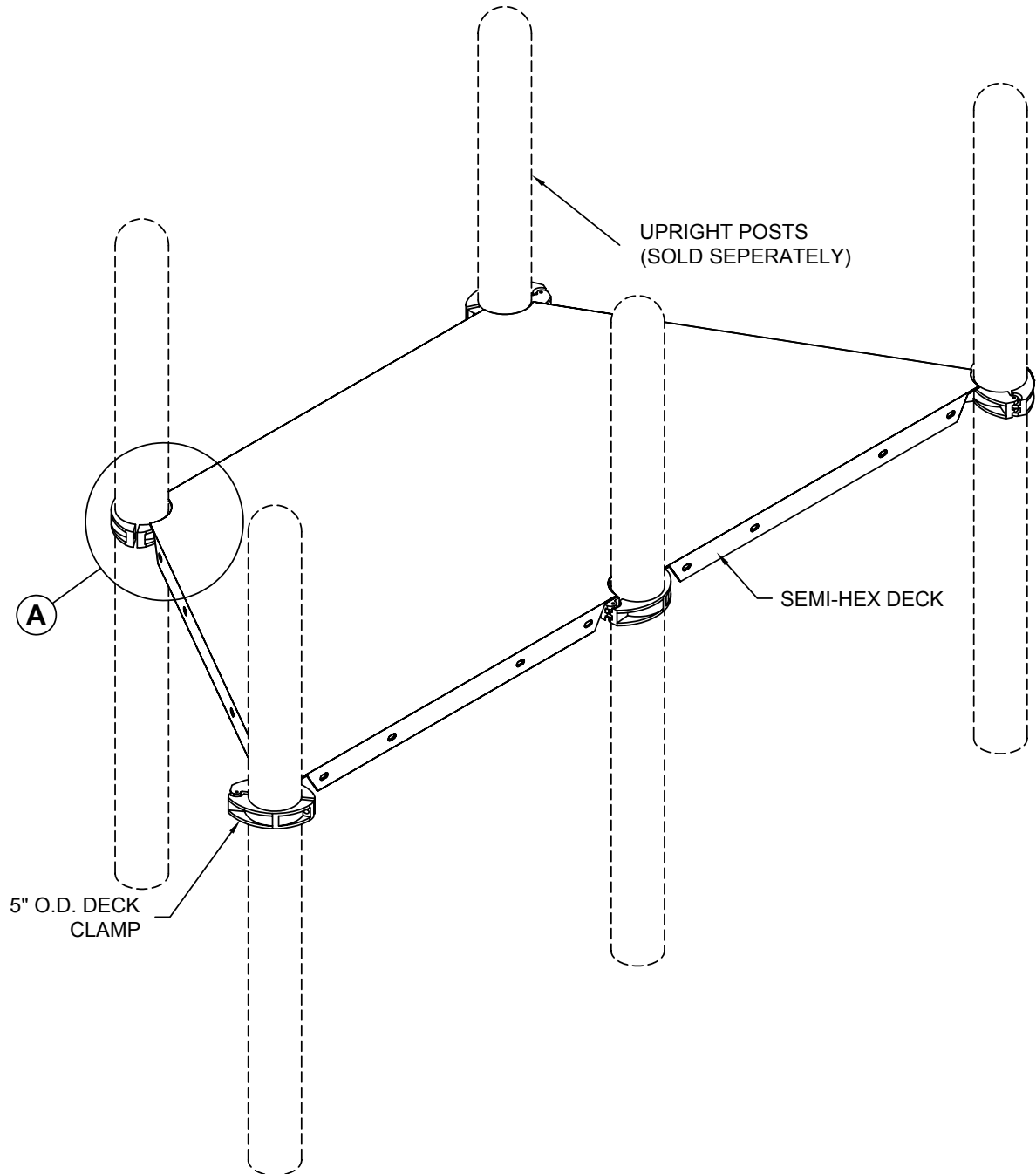

FINISHED ASSEMBLY

MODEL NO. 60057 Semi-Hex Deck

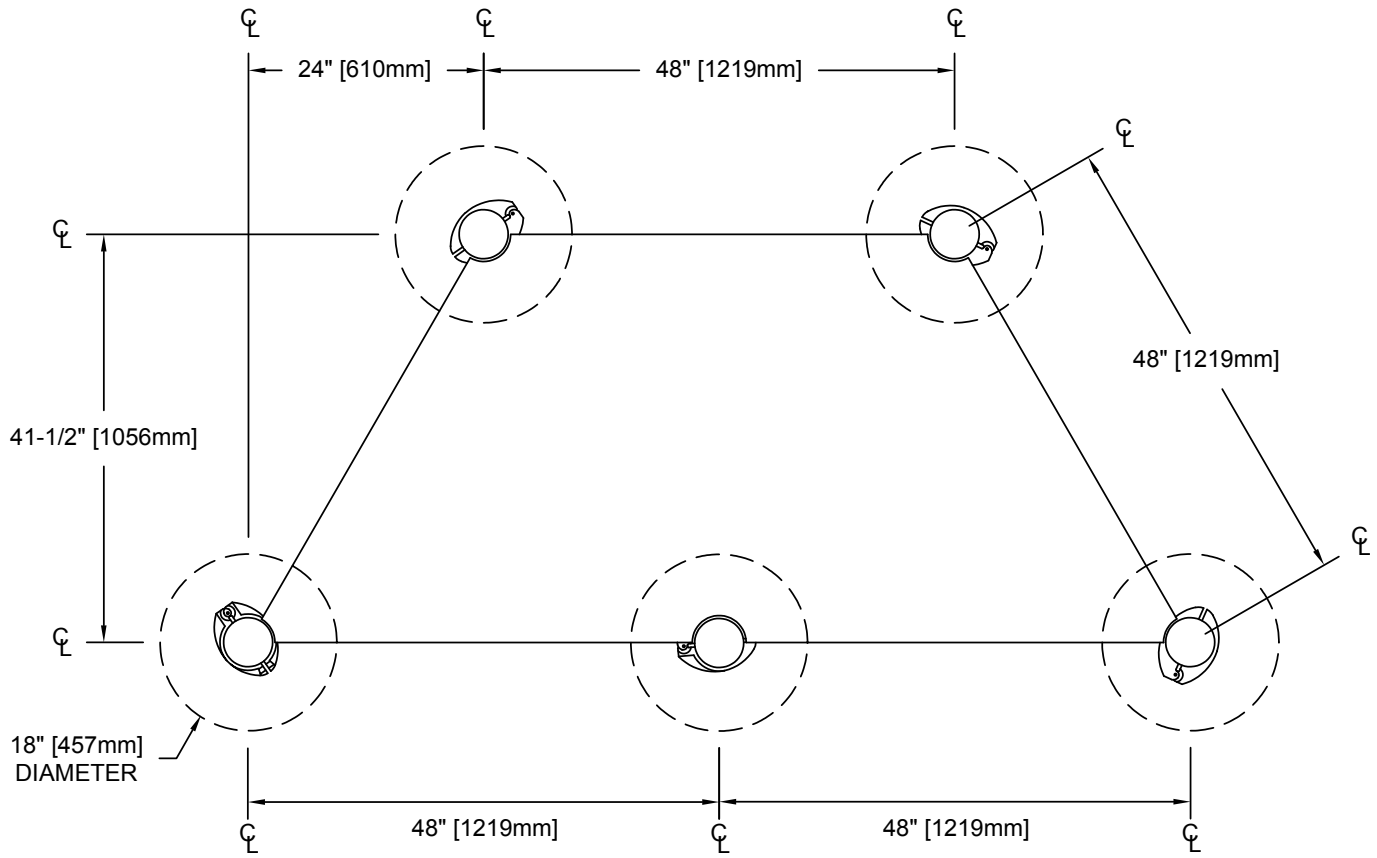

PLAN VIEW

MODEL NO. 60057 Semi-Hex Deck

DETAIL 'A'

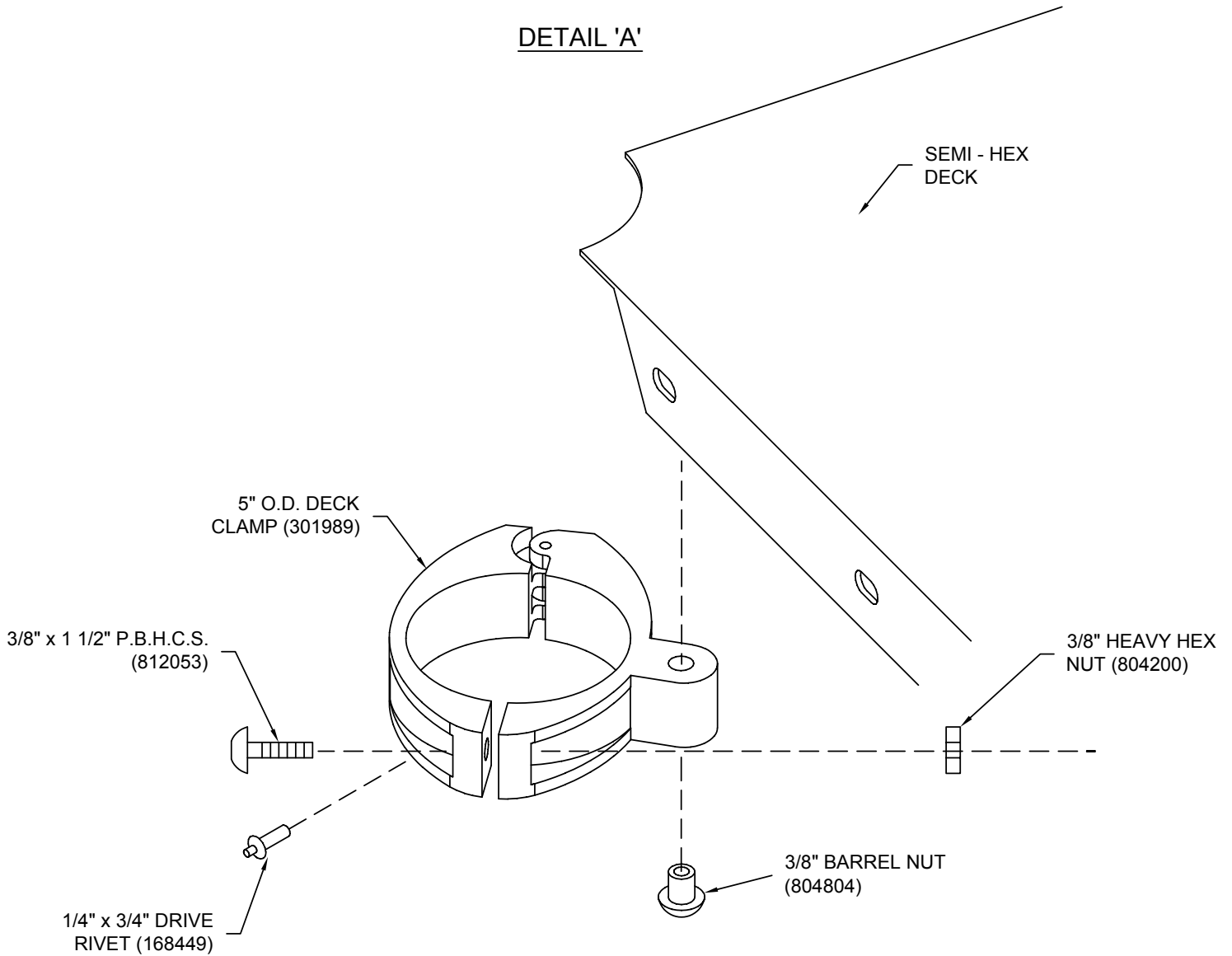

SEMI-HEX DECK ASSEMBLY