

MODEL NO. 60067 Playwheel with Panel Stub

PARTS LIST

DESCRIPTION	No. REQ'D	PART NUMBER
Playwheel with Panel Stub	1	301766
Hardware Complete	1	302429
3/8" Flat Washer	1	817410*
3/8" x 1 3/4" P.B.H.C.S. with Patch	1	812054*

**Unless Otherwise Specified, All Units of Measure are Each
*Included in Hardware**

Warning: Small parts and hardware items may present a potential choking hazard. Promptly remove all unused parts from play area.

SPECIFICATIONS:

Playwheel is an all-welded aluminum wheel free-turning. A grease impregnated bronze bushing is pressed into the shaft to provide smooth turning. The entire Playwheel receives a baked-on polyester powder-coated finish.

All hardware is stainless steel.

Weight: 5 lb. / 2.3 kg

INSTALLATION INSTRUCTIONS:

1. Attach Playwheel to Wall Panel as shown using 3/8" x 1 3/4" P.B.H.C.S. with Patch with 3/8" Flat Washer.
2. When the assembly is finished and satisfactory, Eliminate sharp points and sharp edges (burring) on installed hardware like bolts, nuts, etc. Install resilient surfacing material within the use zone of play structure in accordance with ASTM specifications F1292 appropriate for the fall height of each structure. Refer to the Safe Guidelines.

MAINTENANCE PROCEDURE:

Periodically check hardware for tightness, and tighten as necessary. Always check all parts for breakage or wear, and immediately put equipment out of service until any faulty parts found are repaired or replaced. Also Check all metal parts for rust, paint loss and touch-up if necessary with paint. Check for welded areas and verify integrity. Check periodically resilient surfacing for appropriate depth and remove extraneous materials that could cause injury, infection, or disease. Maintain detailed installation, inspection, maintenance, and repair records for each public-use playground equipment.

MODEL NO. 60067 Playwheel with Panel Stub

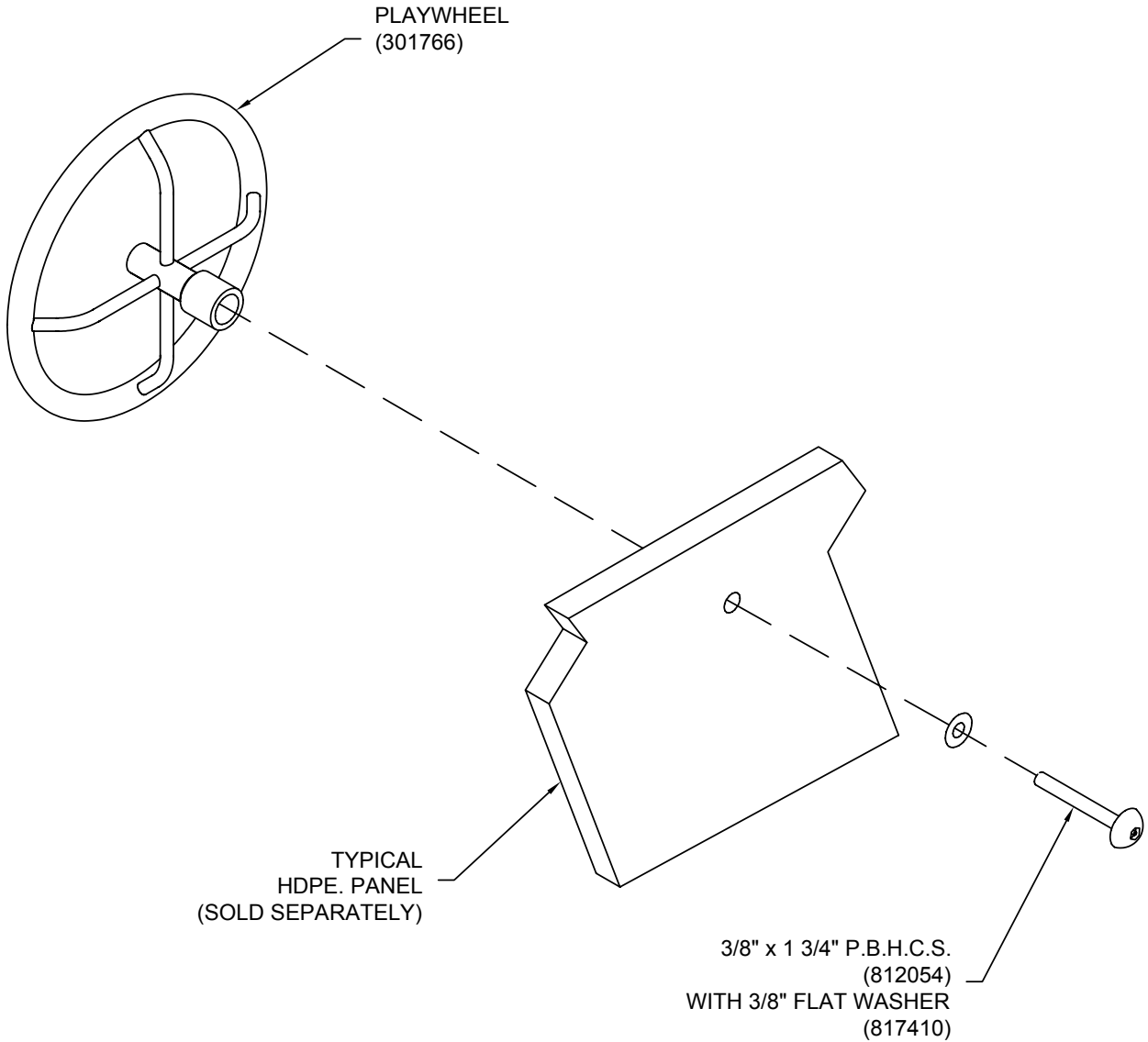

ELEVATION VIEW