

MODEL NO. 60075 Supermax Pedal Pusher

PARTS LIST

DESCRIPTION	No. REQ'D	PART NUMBER
Pre-Assembled Pedal Pusher	2	302631
Cycle Paddle Panel	4	306799
<i>Hardware Complete</i>	1	302558
5" O.D. Half Clamp	8	301001*
1/4" x 3/4" Drive Rivet	8	168449*
3/8" Flat Washer	40	817410*
3/8" Plastic Washer	8	817613*
3/8" x 1 1/2" P.B.H.C.S. w/Patch	24	812053*
3/8" Heavy Hex Nut	16	804200*
3/8" Barrel Nut	8	804804*
Split Shaft Collar	4	306802*
Anti-Slip Tape	4	302769*

Unless Otherwise Specified, All Units of Measure are Each

**Included in Hardware*

Warning: Small parts and hardware items may present a potential choking hazard. Promptly remove all unused parts from play area. Any bolt end protruding more than two full threads beyond the face of the nut causes risk of clothing entanglement. Promptly cut-off flush, file smooth, and treat to prevent corrosion.

Note: Peen Tee-Nuts and Flatwashers to match radius of pipe after assembly is complete.

Note: Loctite (supplied by others) should be used on all threaded hardware.

INSTALLATION INSTRUCTIONS:

- Select the appropriate Upright Posts to receive the Pedal Pusher. Refer to your overhead drawing for location.
- Attach Pre-Assembled Pedal Pusher to Upright Posts using Half Clamps, 3/8" x 1-1/2" P.B.H.C.S. w/ Patch, 3/8" Flat Washers and 3/8" Heavy Hex Nuts as shown in Assembly Diagram. Attach Paddle Panels (See assembly diagram).
- When the assembly is finished and satisfactory, install Drive Rivets in Half Clamps to ensure Clamps cannot slide down Posts. Refer to Clamp Sub-Assembly for details. **It is very important that all Drive Rivets be installed before allowing use of the equipment, as Clamps are not designed to support substantial weight without them.** Also eliminate sharp points and sharp edges (burring) on installed hardware like bolts, nuts, etc. Install resilient surfacing material within the *use zone* of play structure in accordance with ASTM specifications F1292 appropriate for the fall height of each structure. Refer to the *Safety Guidelines*.

MAINTENANCE PROCEDURE:

Periodically check hardware for tightness, and tighten as necessary. Always check all parts for breakage or wear, and immediately put equipment out of service until any faulty parts are repaired or replaced. Check all decks for Plastisol-coating peeling and touch-up with Plastisol if necessary. Check for holes on deck, clean if necessary. Check periodically resilient surfacing for appropriate depth and remove extraneous materials that could cause injury, infection, or disease. Maintain detailed installation, inspection, maintenance, and repair records for each public-use playground equipment.

MODEL NO. 60075 Supermax Pedal Pusher

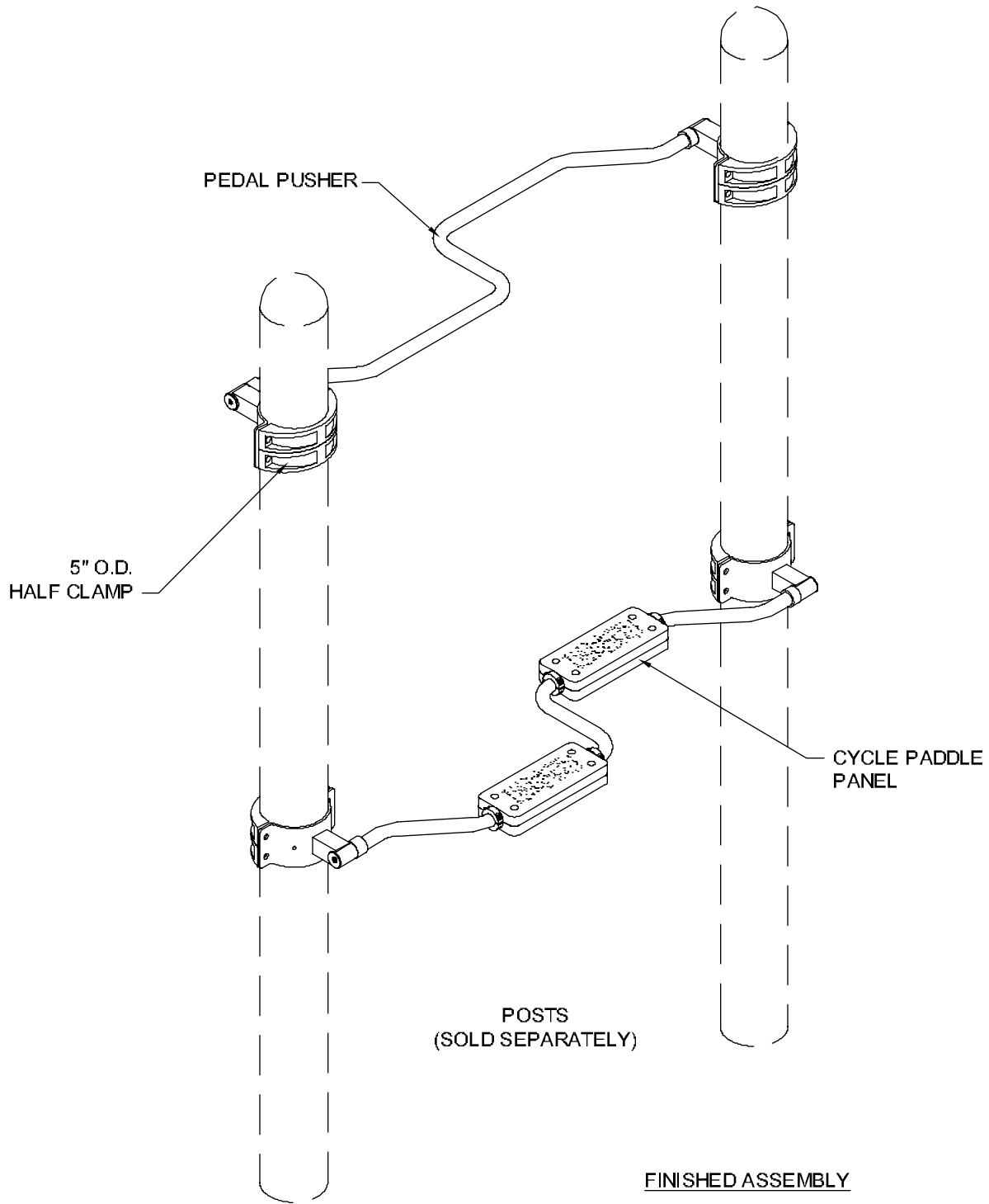

MODEL NO. 60075 Supermax Pedal Pusher

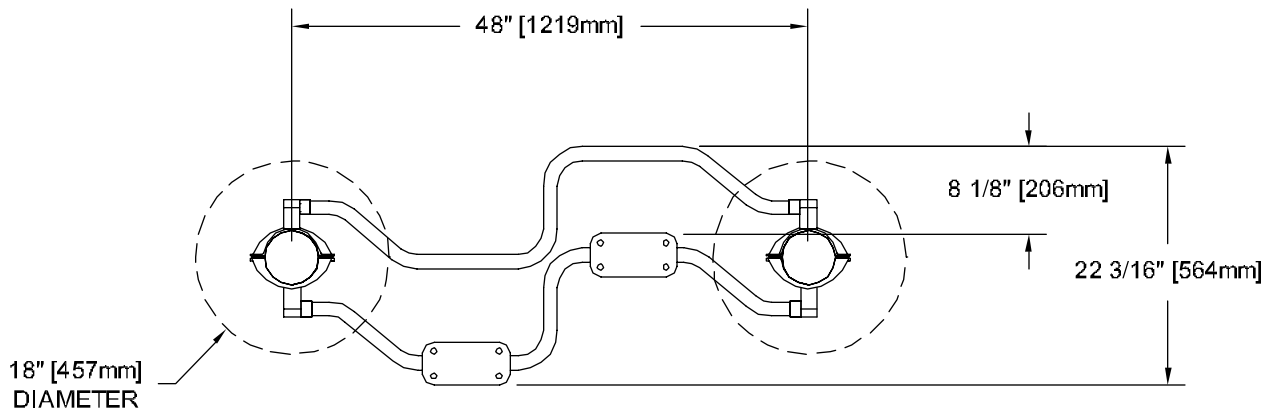

PLAN VIEW

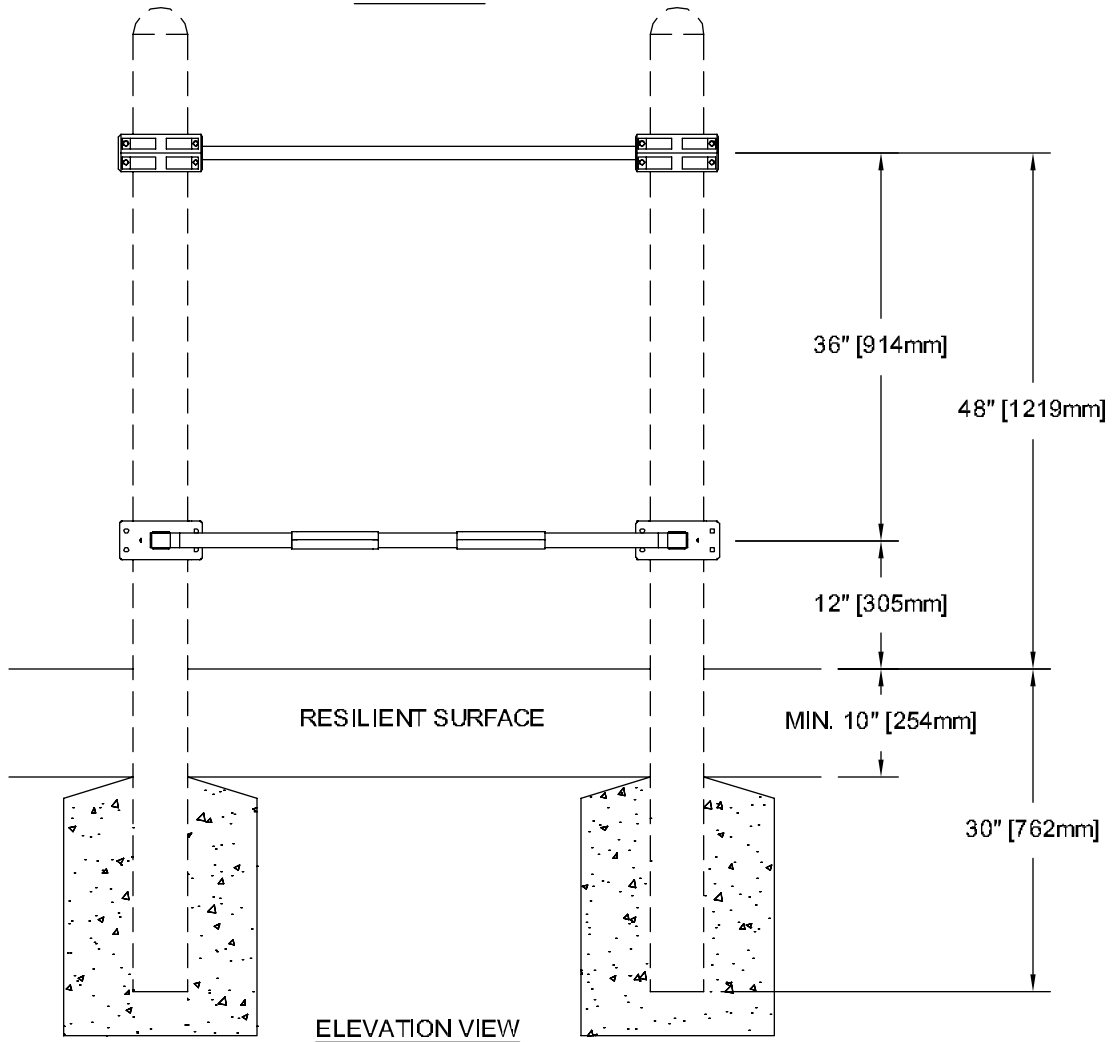

MODEL NO. 60075 Supermax Pedal Pusher

