

## MODEL NO. 60083 Supermax Signal Mountain

### PARTS LIST

DESCRIPTION	No. REQ'D	PART NUMBER
Signal Mountain	1	167048
Climbing Barrier	1	300669
Upper Bracket	1	302646
Center Bracket	1	302650
Lower Bracket	1	302652
<b>Hardware Complete</b>	1	302648
5" O.D. Deck Clamp	2	301989*
1/4" x 3/4" Drive Rivet	2	168449*
3/8" Barrel Nut	2	804804*
3/8" Flat Washer □	2	817410*
3/8" Heavy Hex Nut	2	804200*
3/8" x 1 1/2" P.B.H.C.S. w/Patch	2	812053*
3/8" x 1 3/4" P.B.H.C.S. w/Patch	13	812054*
3/8" Lock Nut	11	804353*
3/8" Flat Washer (1 1/4" O.D.)	2	817424*

*Unless Otherwise Specified, All Units of Measure are Each  
\*Included in Hardware*

**Warning: Small parts and hardware items may present a potential choking hazard. Promptly remove all unused parts from play area.**

#### SPECIFICATIONS:

Signal Mountain is Thermal formed ergonomically design with real rock color and texture. Clamps are cast form a 356 High-Strength Aluminum and coated with a baked-on polyester powder-coated finish. Climbing Barrier is made from 1-5/16" O.D. 14-gauge galvanized tubing with 3/16" "L" brackets and receives a baked-on polyester powder-coated finish after fabrication. Upper, Center and Lower Brackets are formed from 1-5/16" O.D. 14-gauge tubing.

All hardware is stainless steel.

Weight: 120 lbs. / 54.4 kg.

#### Installation Instructions:

**Note:** The Signal Mountain is designed to use with a deck height of 60". Do not over-tighten bolts. To over-tighten may cause buckling or dimpling of some parts. Read installation instructions thoroughly before starting assembly. Pour concrete only after final assembly is completed. Bracing material may be required during installation.

1. Determine which deck is to receive the Signal Mountain. Refer to your overhead drawings for location.
2. Dig hole at locations shown in the assembly diagram.
3. Attach Climbing Barrier to the Uprights using Deck Clamps (Refer to Clamp Sub-assembly Sheet) as shown in the assembly diagram.
4. Attach Upper bracket to Climbing Barrier and Deck as shown in the assembly drawing.
5. Attach the Signal Mountain to deck using the upper Bracket as support as shown in assembly drawing.
6. Attach Center and Lower Brackets as shown in assembly drawing.

## MODEL NO. 60083 Supermax Signal Mountain

7. When the assembly is finished and satisfactory, install Drive Rivets in all Clamps to ensure Clamps cannot slide down Posts. Refer to Clamp Sub-Assembly for details. **It is very important that all Drive Rivets be installed before allowing use of the equipment, as Clamps are not designed to support substantial weight without them.** Also eliminate sharp points and sharp edges (burring) on installed hardware like bolts, nuts, etc. Install resilient surfacing material within the *use zone* of play structure in accordance with ASTM specifications F1292 appropriate for the fall height of each structure. Refer to the *Safety Guidelines*.

### **MAINTENANCE PROCEDURE:**

Periodically check hardware for tightness, and tighten as necessary. Always check all parts for breakage or wear, and immediately put equipment out of service until any faulty parts are repaired or replaced. Check all decks for Plastisol-coating peeling and touch-up with Plastisol if necessary. Check for holes on deck, clean if necessary. Check periodically resilient surfacing for appropriate depth and remove extraneous materials that could cause injury, infection, or disease. Maintain detailed installation, inspection, maintenance, and repair records for each public-use playground equipment.

## MODEL NO. 60083 Supermax Signal Mountain

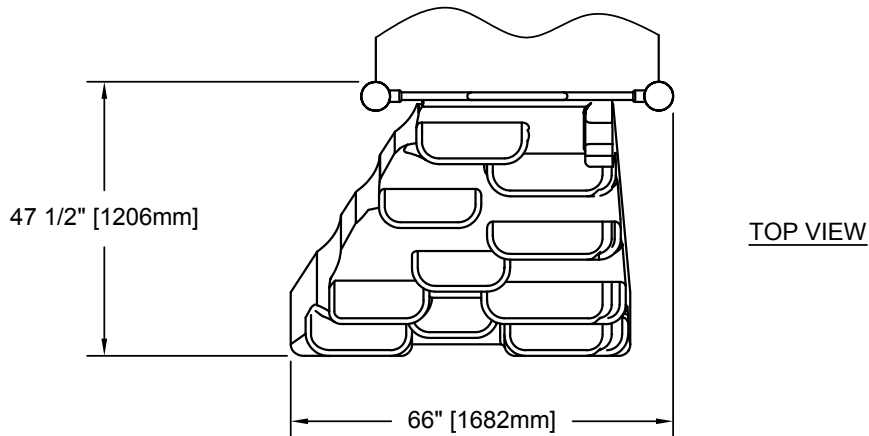
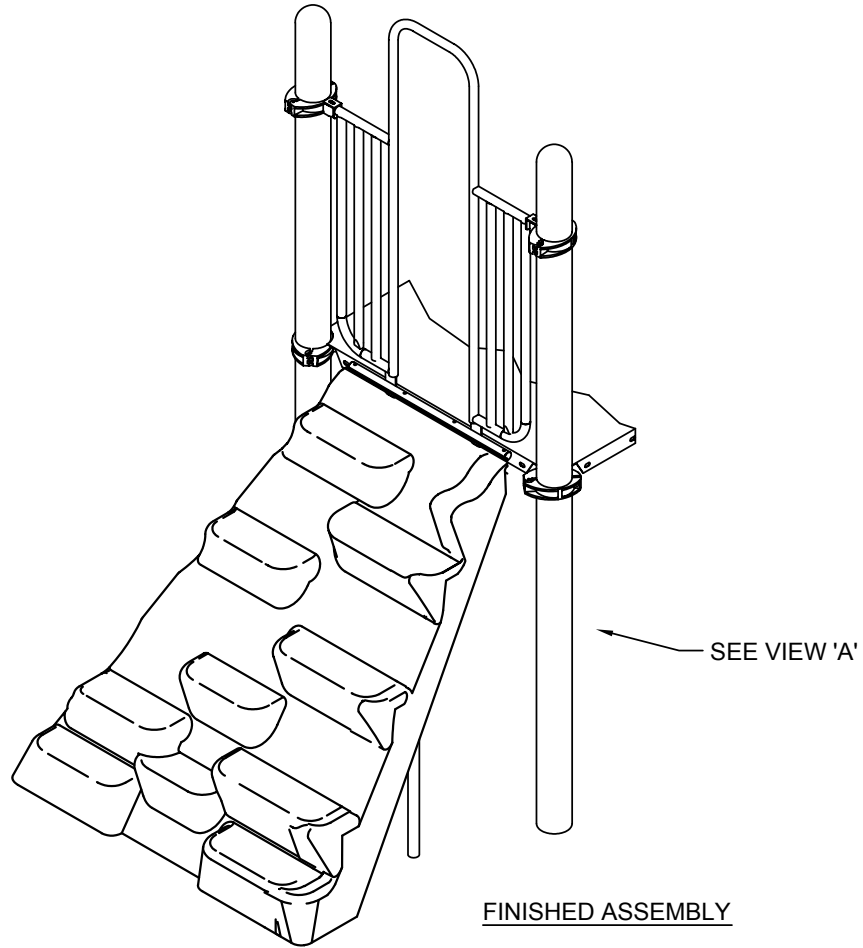

## MODEL NO. 60083 Supermax Signal Mountain

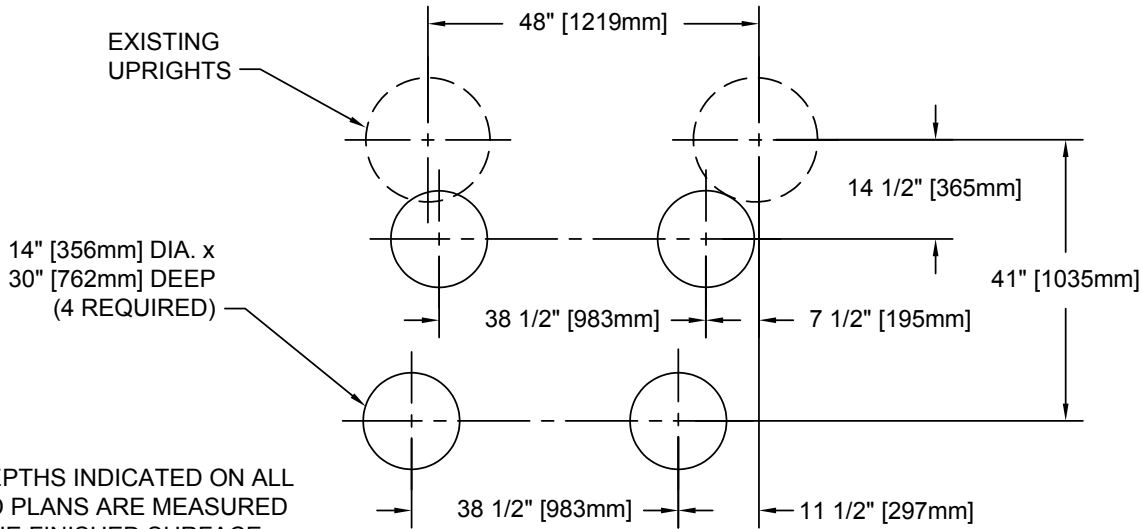

**NOTE:**  
HOLE DEPTHS INDICATED ON ALL  
GROUND PLANS ARE MEASURED  
FROM THE FINISHED SURFACE.

**GROUND PLAN**

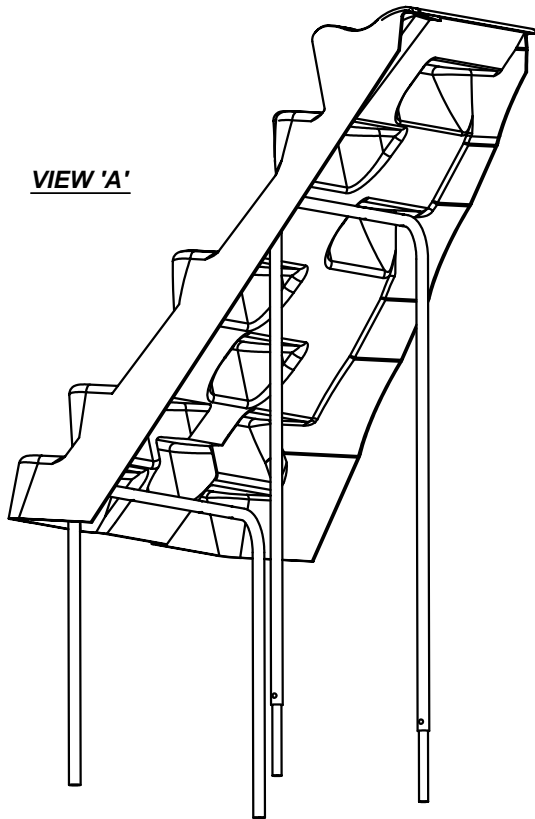

**VIEW 'A'**

3/8" x 1 3/4" P.B.H.C.S.  
w/ PATCH (812054)  
w/ 3/8" LOCK NUT  
(804353)

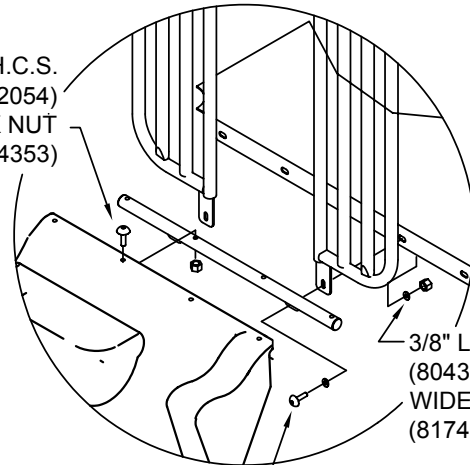

3/8" LOCK NUT  
(804353) w/ 3/8"  
WIDE FLAT WASHER  
(817424)

3/8" x 1 1/2" P.B.H.C.S.  
w/ PATCH (812053)  
w/ 3/8" FLAT WASHER  
(817410)