

MODEL NO. 60086 Pipe Wall w/Playwheel

PARTS LIST

DESCRIPTION	No. REQ'D	PART NUMBER
Pipe Wall	1	305485
Steering Wheel Assembly	1	163235
Hardware Complete	1	302671
5" O.D. Pipe Clamp	4	302030*
3/8" Flatwasher	2	817410*
1/4" x 3/4" Drive Rivet	4	168449*
3/8" Lockwasher	2	817334*
3/8" Heavy Hex Nut	4	804200*
3/8" x 1 1/2" P.B.H.C.S. w/Patch	4	812053*
3/8" x 3/4" P.B.H.C.S. w/Patch	2	812052*
3/8" Acorn Nut	2	804002*
3/8" x 3/8" Set Screw	4	811549*

*Unless Otherwise Specified, All Units of Measure are Each
* Included in Hardware*

Warning: Small parts and hardware items may present a potential choking hazard. Promptly remove all unused parts from play area.

SPECIFICATIONS:

Clamps are cast from a 356 high strength aluminum alloy with a baked on polyester powder-coated finish. Pipe Wall is an all stainless steel welded assembly using 1-5/16" x 14-gauge galvanize tubing. Eight vertical 1-5/16" O.D. tubes are welded to two 1- 5/16" O.D. horizontal tubes and the entire assembly is polyester powder-coat finished. Pipe Wall is designed to provide a 38" high barrier above the deck surface. The steering wheel is molded of a durable proprietary plastic and shall withstand an impact of over 250 foot-pounds. A grease impregnated bronze bushing is pressed into the shaft to provide smooth turning. The steering wheel mounting bracket is formed of 3/16" thick steel and has a powder coat finish. All hardware is stainless steel.

Weight: 70 lb. / 32 kg

INSTALLATION INSTRUCTIONS:

1. Attach two Pipe Clamps to the top of the Pipe Wall. Only slightly tighten set screws in Pipe Clamps (Refer to separate Pipe Clamps instructions).
2. Attach Pipe Wall to post by using Pipe Clamps. Position so that bottom of rail is approximately 1" above deck. Adjust not to conflict with adjacent components. Under no circumstances should distance from top rail of Pipe Wall to deck surface be less than 38". Only slightly tighten top two Pipe Clamps around upright posts.
3. Swing bottom ends of Pipe Wall out and attach other two Pipe Clamps. Fasten bottom Pipe Clamps to upright post. After ensuring Pipe Wall is square and level, tighten all fasteners.
4. When the structure is finished and satisfactory, install Drive Rivets in all clamps to ensure clamps cannot slide down posts. **It is very important that all Drive Rivets be installed prior to allowing use of the equipment, as clamps are not designed to support substantial weight without them.** See Pipe Clamps sub-assembly sheet. Also eliminate sharp points and sharp edges (burring) on installed hardware like bolts, nuts, etc. Install resilient surfacing material within the use zone of play structure in accordance with ASTM specifications F1292 appropriate for the fall height of each structure. Refer to the Safety Guidelines.
5. Attach the Steering Wheel Assembly to the Pipe Wall as shown using two each 3/8"x 3/4" P.B.H.C.S. w/Patch, 3/8" Flatwasher, 3/8" Lockwasher and 3/8" Acorn nut.

MODEL NO. 60086 Pipe Wall w/Playwheel

MAINTENANCE PROCEDURE:

Periodically check hardware for tightness, and tighten as necessary. Always check all parts for breakage or wear, and immediately put equipment out of service until any faulty parts found are repaired or replaced. Check for rust, paint peeling and touch-up if necessary with paint. Check for welded areas and verify integrity. Check periodically resilient surfacing for appropriate depth and remove extraneous materials that could cause injury, infection, or disease. Maintain detailed installation, inspection, maintenance, and repair records for each public-use playground equipment.

MODEL NO. 60086 Pipe Wall w/Playwheel

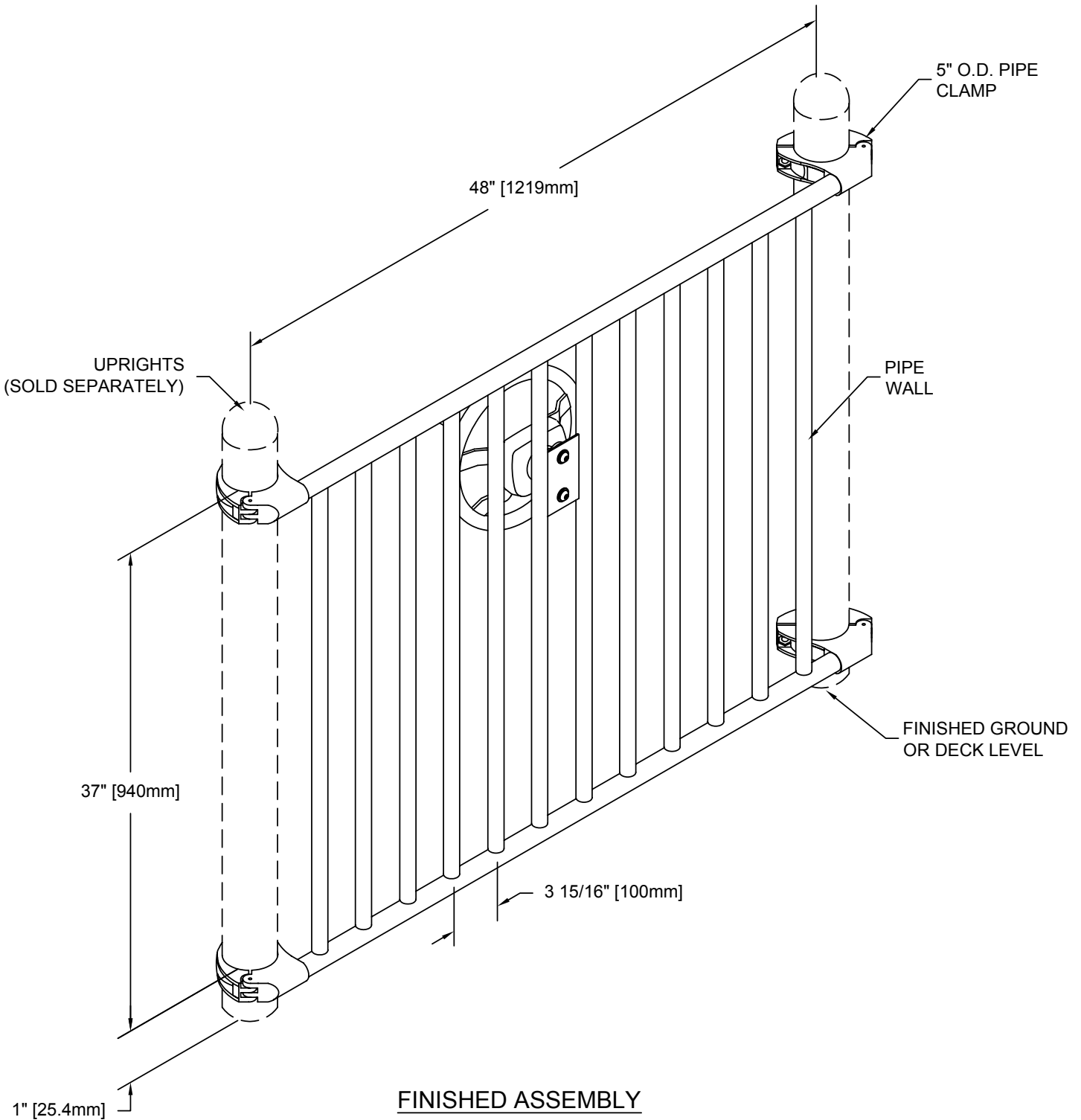

MODEL NO. 60086 Pipe Wall w/Playwheel

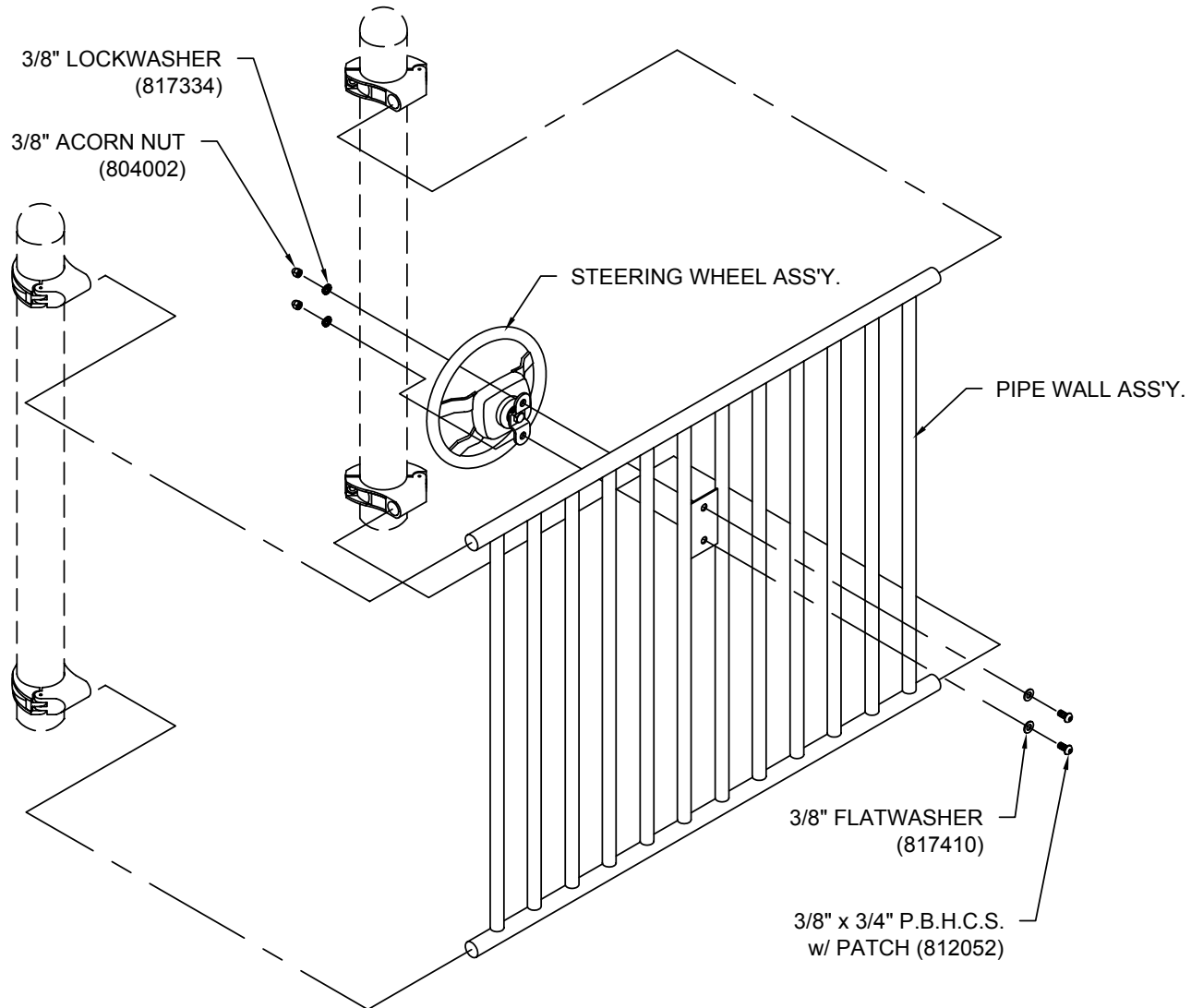

PIPE WALL w/ PLAYWHEEL ASSEMBLY