

MODEL NO. 60092 Transfer Module for 32" Deck

PARTS LIST

DESCRIPTION	No. REQ'D	PART NUMBER
Transfer Single Step	1	300067
Transfer Single Step	1	306269
Transfer Deck 40" x 40"	1	300162
Center Support Post	1	301660
Support Leg (24")	2	300752
Transfer Hand Rail	2	302690
Corner Support Leg (36")	1	301652
Transfer Handle w/ Big Loop	1	301668
Hardware Complete	1	302684
5" O.D. Pipe Clamp	2	302030*
1/4" x 3/4" Drive Rivet	2	168449*
3/8" Heavy Hex Nut	2	804200*
3/8" x 1" P.B.H.C.S. w/ Patch	8	812050*
3/8" x 1 1/2" P.B.H.C.S. w/ Patch	6	812053*
3/8" x 1 1/4" P.B.H.C.S. w/ Patch	3	812051*
3/8" x 3/4" P.B.H.C.S. w/ Patch	12	812052*
3/8" Lock Nut	11	804353*
3/8" x 3/8" Set Screw	2	811549*
3/8" Flat Washer (1 1/4" O.D.)	23	817424*
3/8" Lockwasher	16	817334*
3/8" T-Nut	16	804556*
3/8" Flatwasher	7	817410*

**Unless Otherwise Specified, All Units of Measure are Each
*Included in Hardware**

Warning: Small parts and hardware items may present a potential choking hazard. Promptly remove all unused parts from play area. Any bolt end protruding more than two full threads beyond the face of the nut causes risk of clothing entanglement. Promptly cut-off flush, file smooth, and treat to prevent corrosion.

Note: Peen Tee-Nuts and Flatwashers to match radius of pipe after assembly is complete.

Note: Loctite (supplied by others) should be used on any non-patch hardware.

SPECIFICATIONS:

Clamps are cast from 356 high-strength aluminum alloy with a baked on polyester powder-coated finish. Transfer Deck and Steps are formed from 11-gauge H. R. Steel Sheet. All Under Bracing is made from 1/8" X 1-1/2" H. R. Steel Strip. Perforation diameter is 1/4" after Plastisol coating. Handrails are fabricated from 1-5/16" O.D. x 14-gauge galvanized steel tubing. Support posts are 1-5/8" O.D. x 14-gauge for lower step, and 2-3/8" O.D. 10-gauge for Transfer Deck. Transfer Handle is fabricated from 1-5/16" O.D. x 14-gauge galvanized steel tubing bend into loop and steel welded to 2-3/8" O.D. x 10-gauge post and 5-3/8" x 5-3/8" x 3/16" galvanized plate for attachment. The entire Transfer Handle is coated with a baked on polyester powder-coated finish.

Primary hardware is stainless steel.

Weight: 247 lbs. / 111 kg.

INSTALLATION INSTRUCTIONS:

1. Dig footing holes at appropriate locations as shown in the Footing Diagram.
2. Attach Transfer Deck Center Support Post and Outside Corner Support Post to Transfer Deck underside and side flange. See Detail "C" and Detail "E". Attach 24" Transfer Support Legs to Lower Transfer Step. See Detail "C".
3. Attach the lower Transfer Step to Transfer Deck. See Detail "A".

MODEL NO. 60092 Transfer Module for 32" Deck

4. Position assembly in dug holes and match upper Transfer Step flange holes to 32" high deck flange holes and fasten using Detail "A".
5. Attach Handrails as shown using 5" O.D. Pipe Clamps (refer to Clamp Detail Page and Detail "B"). Then attach the Transfer Handle to the corner of Transfer Deck . See Detail "D". Its edge should be at least 1/4" away from deck edge.
6. Plumb and level the entire assembly and brace in position. Tighten Pipe Clamp fasteners.
7. Pour concrete footings within 4" to the top and taper away from support posts to allow water drainage. Allow curing at least 48 hours before use.
8. When the structure is finished and satisfactory, install Drive Rivets in all clamps to ensure clamps can not slide down posts. See Pipe Clamps sub-assembly sheet. **It is very important that all Drive Rivets be installed prior to allowing use of equipment, as clamps are not designed to support substantial weight without them** . Eliminate sharp points and sharp edges (burring) on installed hardware like bolts, nuts, etc. Install resilient surfacing material within the use zone of play structure in accordance with ASTM specifications F1292 appropriate for the fall height of each structure. Refer to the Safety Guidelines.

Note: To cushion accidental falls by children, **Park Structures, Inc.** strongly recommends that the area under and around the play structure must be covered with a resilient material, such as sand, mulch, etc., to a minimum depth of 10" for sand. Approved rubber safety matting (such as our *Kid Safe Play Tiles*) can also be used. For details, please refer to your Safety Guidelines, provided within the assembly instruction packet.

Note: Loctite (supplied by others) should be used on any non-patch hardware.

MAINTENANCE PROCEDURE:

Periodically check hardware for tightness, and tighten as necessary. Always check all parts for breakage or wear, and immediately put equipment out of service until any faulty parts are repaired or replaced. Check all decks for Plastisol-coating peeling and touch-up with Plastisol if necessary. Check for holes on deck, clean if necessary. Check periodically resilient surfacing for appropriate depth and remove extraneous materials that could cause injury, infection, or disease. Maintain detailed installation, inspection, maintenance, and repair records for each public-use playground equipment.

MODEL NO. 60092 Transfer Module for 32" Deck

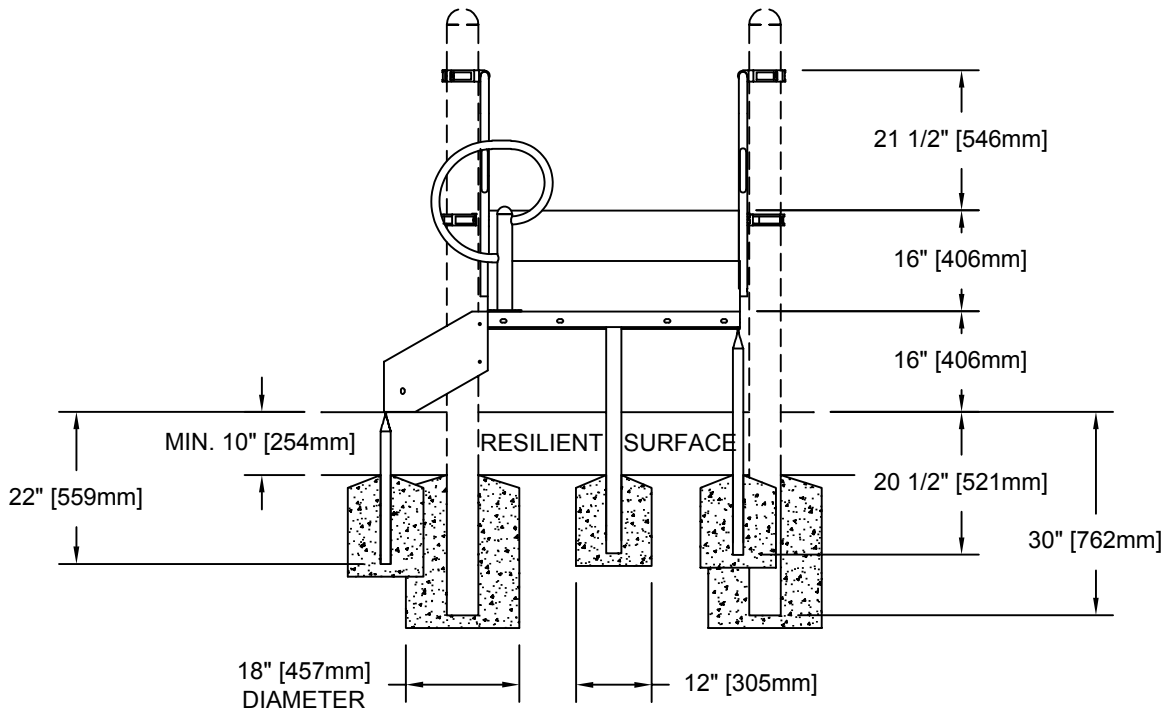
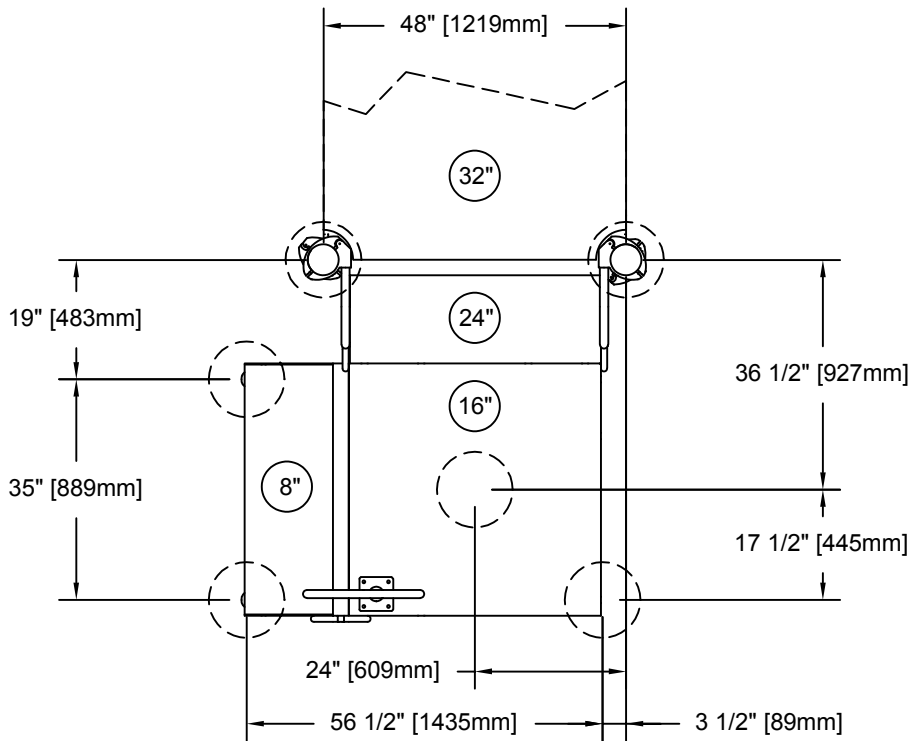

ELEVATION VIEW

MODEL NO. 60092 Transfer Module for 32" Deck

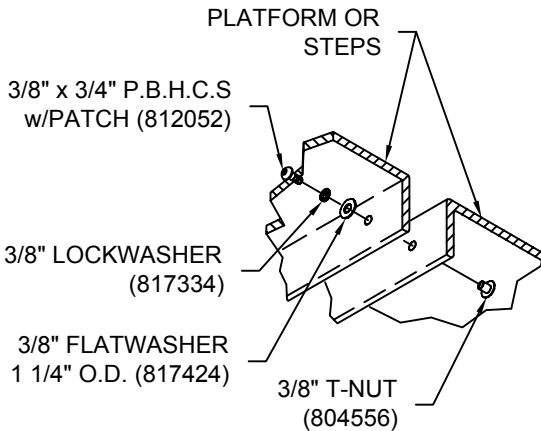
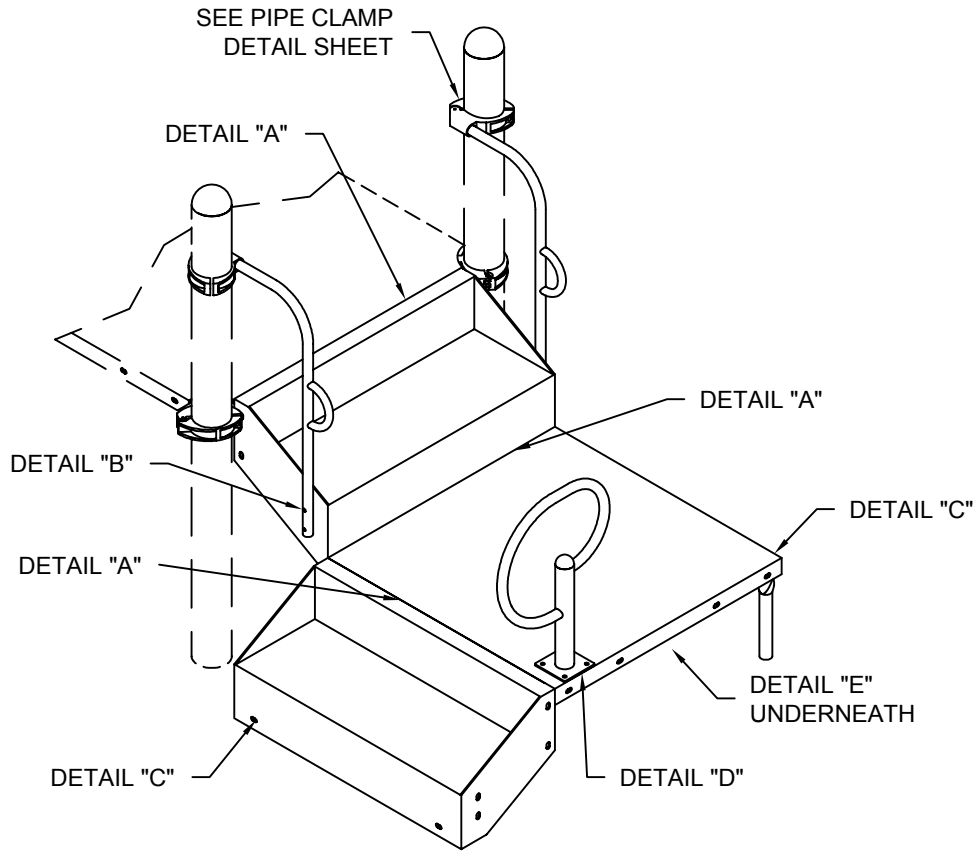

DETAIL "A"

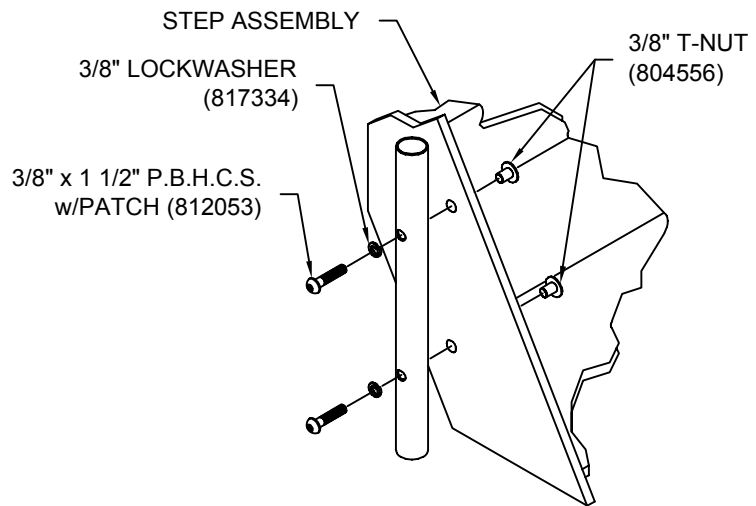

DETAIL "B"

MODEL NO. 60092 Transfer Module for 32" Deck

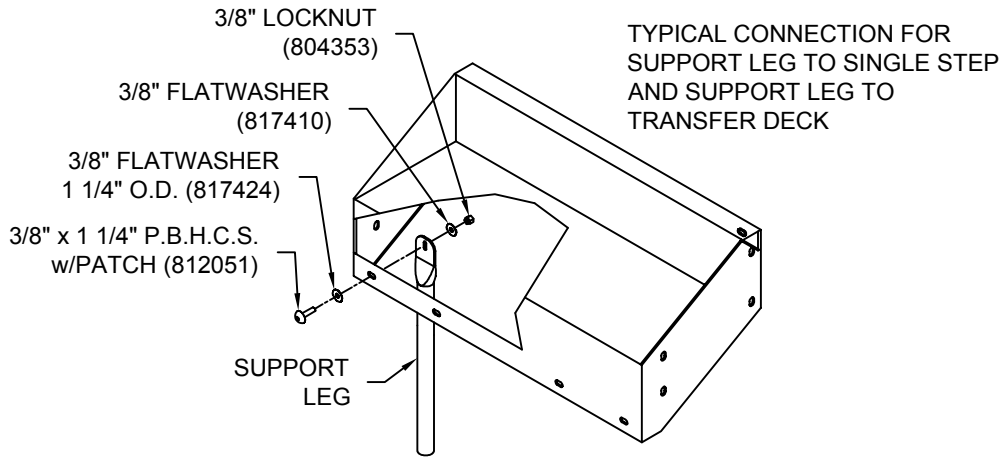

DETAIL "C"

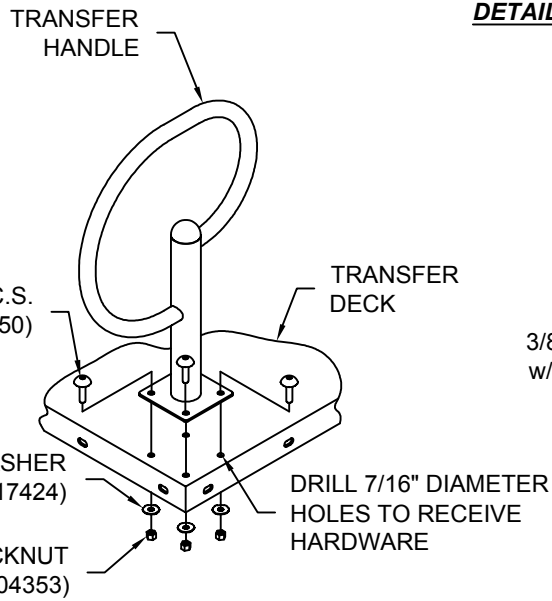

DETAIL "D"

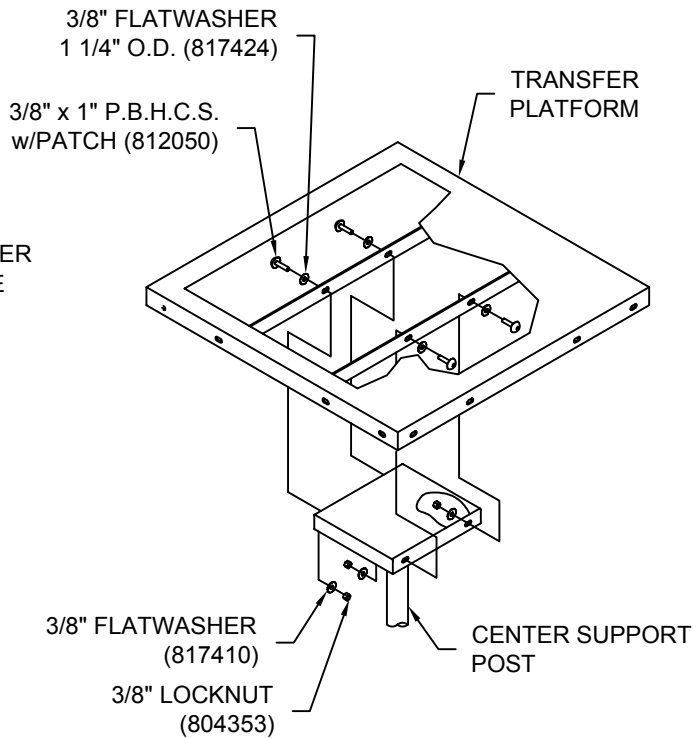

DETAIL "E"