

MODEL NO. 60092 Transfer Module for 32" Deck

PARTS LIST

| DESCRIPTION | No. REQ'D | PART NUMBER |
|-----------------------------------|-----------|-------------|
| Transfer Single Step | 2 | 300067 |
| Transfer Deck 40" x 40" | 1 | 300162 |
| Center Support Post | 1 | 301660 |
| Support Leg (24") | 2 | 300752 |
| Transfer Hand Rail | 2 | 302690 |
| Corner Support Leg (36") | 1 | 301652 |
| Transfer Handle w/ Big Loop | 1 | 301668 |
| Hardware Complete | 1 | 302684 |
| 5" O.D. Pipe Clamp | 2 | 302030* |
| 1/4" x 3/4" Drive Rivet | 2 | 168449* |
| 3/8" Heavy Hex Nut | 2 | 804200* |
| 3/8" x 1" P.B.H.C.S. w/ Patch | 4 | 812050* |
| 3/8" x 1 1/2" P.B.H.C.S. w/ Patch | 10 | 812053* |
| 3/8" x 1 1/4" P.B.H.C.S. w/ Patch | 11 | 812051* |
| 3/8" x 2 1/4" P.B.H.C.S. w/ Patch | 2 | 812056* |
| 3/8" Lock Nut | 25 | 804353* |
| 3/8" x 3/8" Set Screw | 2 | 811549* |
| 3/8" Flat Washer (1 1/4" O.D.) | 44 | 817424* |

*Unless Otherwise Specified, All Units of Measure are Each
* Included in Hardware*

Warning: Small parts and hardware items may present a potential choking hazard. Promptly remove all unused parts from play area.

Material

Clamps are cast from 356 high-strength aluminum alloy with a baked on polyester powder-coated finish. Transfer Deck and Steps are formed from 11-gauge H. R. Steel Sheet. All Under Bracing is made from 1/8" X 1-1/2" H. R. Steel Strip. Perforation diameter is 1/4" after Plastisol coating. Handrails are fabricated from 1-5/16" O.D. x 14-gauge galvanized steel tubing. Support posts are 1-5/8" O.D. x 14-gauge for lower step, and 2-3/8" O.D. 10-gauge for Transfer Deck. Transfer Handle is fabricated from 1-5/16" O.D. x 14-gauge galvanized steel tubing bend into loop and stainless steel welded to 2-3/8" O.D. x 10-gauge post and 5-3/8" x 5-3/8" x 3/16" galvanized plate for attachment. The entire Transfer Handle is coated with a baked on polyester powder-coated finish.

All hardware is stainless steel.

Weight: 314 lbs. / 143 kg.

Installation

1. Dig footing holes at appropriate locations as shown in the Footing Diagram.
2. Attach Transfer Deck Center Support Post and Outside Corner Support Post to Transfer Deck underside and side flange. Attach 24" Transfer Support Legs to Lower Transfer Step using 3/8" X 1-1/4" P.B.H.C.S. w/ Patch, 3/8" Flat Washers (1 1/4" O.D.) and 3/8" Lock Nuts as shown in the assembly drawing.
3. Attach the lower Transfer Step to Transfer Deck using 3/8" x 1-1/2" P.B.H.C.S. w/ Patch, 3/8" Flat Washers (1 1/4" O.D.) and 3/8" Lock Nuts as shown.

MODEL NO. 60092 Transfer Module for 32" Deck

4. Position assembly in dug holes and match upper Transfer Step flange holes to 32" high deck flange holes and fasten using 3/8" X 1-1/4" P.B.H.C.S. w/ Patch, 3/8" Flat Washers(1 1/4" O.D.) and 3/8" Lock Nuts as shown in the assembly diagram.
5. Attach Handrails as shown using 5" O.D. Pipe Clamps (refer to sub-assembly for detail), 3/8" X 2-1/4" P.B.H.C.S. w/ Patch, 3/8" Lock Nuts and 3/8" Flat Washers(1 1/4" O.D.). Then attach the Transfer Handle to the corner of Transfer Deck by reaming out the Plastisol on the existing punched holes and using 3/8" X 1" P.B.H.C.S. w/ Patch, 3/8" Flat Washers(1 1/4" O.D.) and 3/8" Lock Nuts as shown. NOTE: Attach the Transfer Handle as close to corner as possible using existing punched holes. Its edge should be at least 1/4" away from deck edge.
6. Plumb and level the entire assembly and brace in position. Tighten Pipe Clamp fasteners.
7. Pour concrete footings within 4" to the top and taper away from support posts to allow water drainage. Allow curing at least 48 hours before use.
8. When the structure is finished and satisfactory, install Drive Rivets in all clamps to ensure clamps can not slide down posts. See Pipe Clamps sub-assembly sheet. **It is very important that all Drive Rivets be installed prior to allowing use of equipment, as clamps are not designed to support substantial weight without them.** Eliminate sharp points and sharp edges (burring) on installed hardware like bolts, nuts, etc. Install resilient surfacing material within the use zone of play structure in accordance with ASTM specifications F1292 appropriate for the fall height of each structure. Refer to the Safety Guidelines.

Note: To cushion accidental falls by children, *Park Structures, Inc.* strongly recommends that the area under and around the play structure must be covered with a resilient material, such as sand, mulch, etc., to a minimum depth of 10" for sand. Approved rubber safety matting (such as our *Kid Safe Play Tiles*) can also be used. For details, please refer to your Safety Guidelines, provided within the assembly instruction packet.

MAINTENANCE PROCEDURE:

Periodically check hardware for tightness, and tighten as necessary. Always check all parts for breakage or wear, and immediately put equipment out of service until any faulty parts are repaired or replaced. Check all decks for Plastisol-coating peeling and touch-up with Plastisol if necessary. Check for holes on deck, clean if necessary. Check periodically resilient surfacing for appropriate depth and remove extraneous materials that could cause injury, infection, or disease. Maintain detailed installation, inspection, maintenance, and repair records for each public-use playground equipment.

MODEL NO. 60092 Transfer Module for 32" Deck

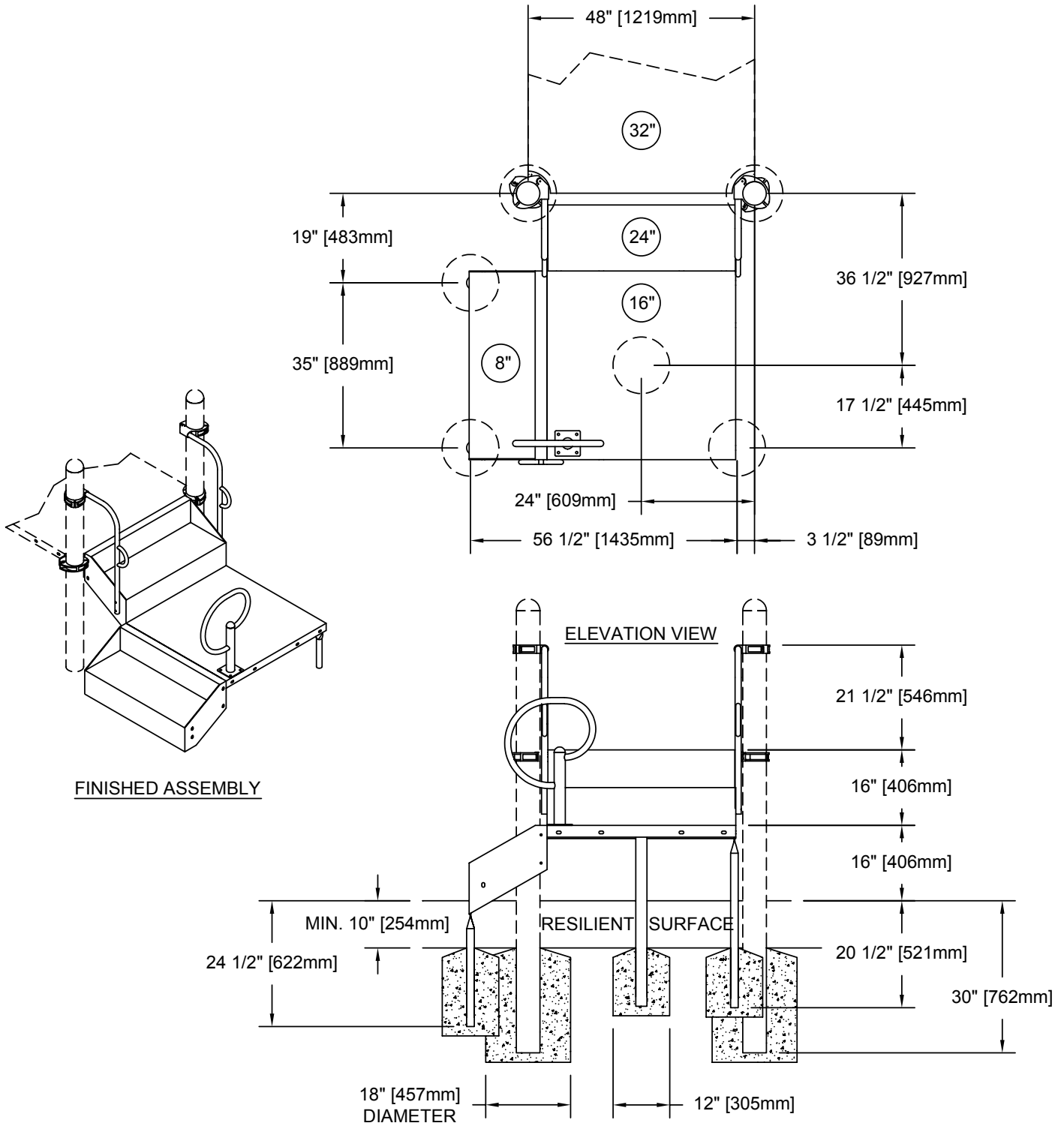

MODEL NO. 60092 Transfer Module for 32" Deck

