

MODEL NO. 60106 Mount Everest Sliding Pole

PARTS LIST

DESCRIPTION	No. REQ'D	PART NUMBER
Mount Everest Sliding Pole	1	300938
Hardware Complete	1	302794
5" O.D. Half Clamp	1	301001*
1/4" x 3/4" Drive Rivet	2	168449*
3/8" Flat Washer	4	817410*
3/8" X 1 1/4" P.B.H.C.S. w/ Patch	2	812051*
3/8" Lock Nut	2	804353*

*Unless Otherwise Specified, All Units of Measure are Each
* Included in Hardware*

Warning: Small parts and hardware items may present a potential choking hazard. Promptly remove all unused parts from play area.

SPECIFICATIONS:

Half Clamp is cast from a 356 high-strength aluminum alloy with a baked-on polyester powder-coated finish. Sliding Pole is fabricated from 1-5/8" O.D. 14-gauge galvanized steel tubing, stainless steel welded to a 5" O.D. steel Half Clamp for attachment and receives a baked-on polyester powder-coated finish.

All hardware is stainless steel.

Weight: 23 lbs. / 10.5 kg.

Installation Instructions:

NOTE: This Model is designed to use as an addition to Model No. 60104 Mount Everest-96".

1. Locate the Post intended to receive the Mount Everest Sliding Pole. Dig footing as shown in the assembly diagram. Refer to your overhead drawing for location.
2. Attach Sliding Pole to Post approximately 115" above finished ground level using Half Clamp, 3/8" x 1-1/4" P.B.H.C.S. w/ Patch with 3/8" Flat Washers and 3/8" Lock Nuts with 3/8" Flat Washers as shown. Loosely tighten Clamps.
3. When the assembly is finished and satisfactory, install Drive Rivets in all clamps to ensure clamps cannot slide down posts. See Pipe Clamp sub-assembly sheet. **It is very important that all Drive Rivets be installed prior to allowing use of the equipment, as clamps are not designed to support substantial weight without them.** Eliminate sharp points and sharp edges (burring) on installed hardware like bolts, nuts, etc. Install resilient surfacing material within the *use zone* of play structure in accordance with ASTM specifications F1292 appropriated for the fall height of each structure. Refer to the *Safety Guidelines*.

MAINTENANCE PROCEDURE:

Periodically check hardware for tightness, and tighten as necessary. Always check all parts for breakage or wear, and immediately put equipment out of service until any faulty parts are repaired or replaced. Check all decks for Plastisol-coating peeling and touch-up with Plastisol if necessary. Check for holes on deck, clean if necessary. Check periodically resilient surfacing for appropriate depth and remove extraneous materials that could cause injury, infection, or disease. Maintain detailed installation, inspection, maintenance, and repair records for each public-use playground equipment.

MODEL NO. 60106 Mount Everest Sliding Pole

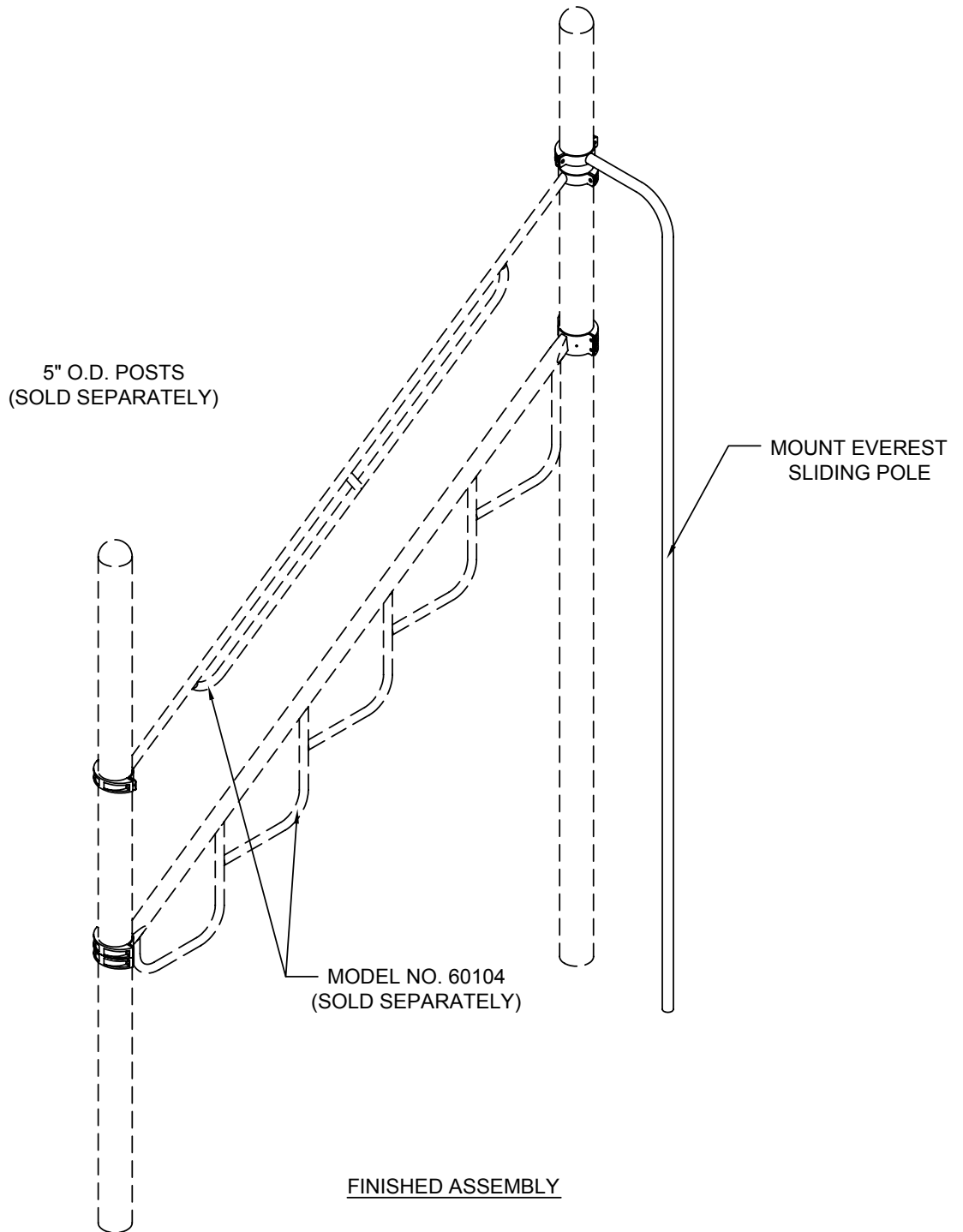

MODEL NO. 60106 Mount Everest Sliding Pole

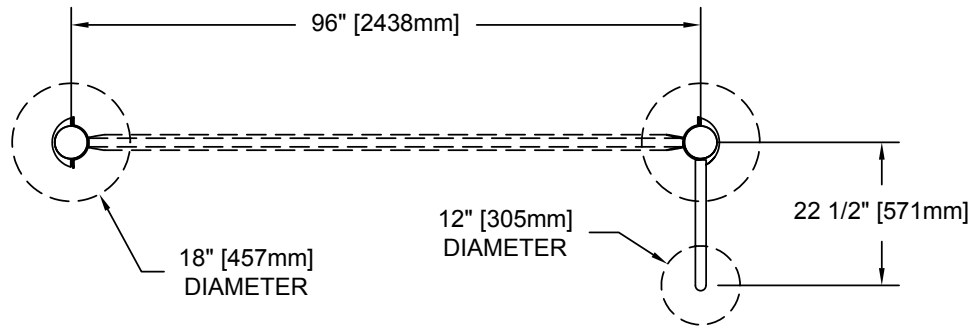

FOOTING DIAGRAM

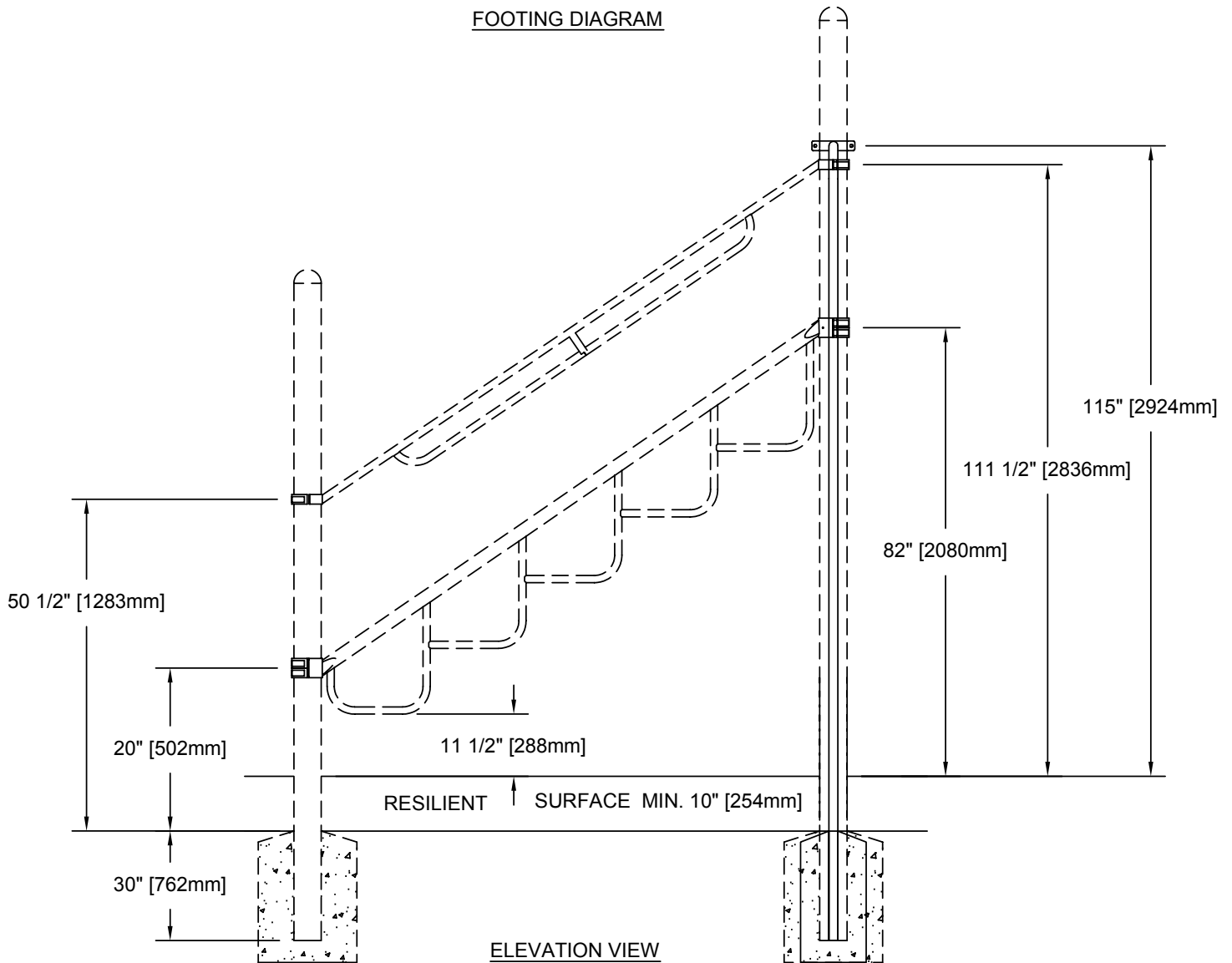

ELEVATION VIEW