

MODEL NO. 60114 Hexagon Deck

PARTS LIST

DESCRIPTION	No. REQ'D	PART NUMBER
Semi-Hex Platform	2	300185
Center Post	1	302866
Hardware Complete	1	302846
5" O.D. Deck Clamp	6	301989*
1/4" x 3/4" Drive Rivet	6	168449*
3/8" Barrel Nut	6	804804*
3/8" Flat Washer	4	817410*
3/8" Heavy Hex Nut	6	804200*
3/8" X 1 1/4" P.B.H.C.S. w/ Patch	8	812051*
3/8" X 1 1/2" P.B.H.C.S. w/ Patch	6	812053*
3/8" Lock Nut	10	804353*
3/8" Flatwasher (1 1/4" O.D.)	16	817424*

*Unless Otherwise Specified, All Units of Measure are Each
* Included in Hardware*

Warning: Small parts and hardware items may present a potential choking hazard. Promptly remove all unused parts from play area.

SPECIFICATIONS:

Clamps are cast from a 356 high-strength aluminum alloy with a baked-on polyester powder-coated finish. Deck is fabricated from pre-punched steel sheet 11-gauge thickness with steel flat support bars welded underneath to increase strength. After welding, the entire platform is Plastisol-coated with a thickness of 50 to 80 mils on top wear surface. Average perforation size is 5/16" diameter after coating. Center Post is fabricated from 3/8" flat steel stainless steel welded to 2-3/8" O.D. 10-gauge galvanized steel tubing. Center Post receives a baked-on polyester powder-coated finish after fabrication.

All hardware is stainless steel.

Weight: 290 lb. / 131.8 kg

INSTALLATION INSTRUCTIONS:

NOTE: prevent bolts end projecting (protruding) beyond the face of the nuts no more than two full threads.

- Place Upright Post in dug holes at appropriate height per Upright Post installation instructions. Get the height required for the deck from the Plan View Diagram; use a felt-tip marker to mark the top of the Deck Clamp on all six posts.
HINT: If this is the first Deck of the structure, locate and concrete one Post only (preferably the most shared Post, if this Deck is part of a multi deck group), ensuring it is plumb and at the right height. After it has had a chance to set, place one corner of the Deck against the Post and mark the location of the adjacent Post. Concrete the second Post. Continue this procedure for all six Posts while leaving the Deck on the ground. The deck has been used as its own template, and the deck is now easily attached as two of its Posts are already in place.
- Attach Semi-Hex Decks together using 3/8"X1-1/4" P.B.H.C.S. w/ Patch with 3/8" Flatwashers (1 1/4" O.D.) and 3/8" Lock Nuts with 3/8" Flatwashers (1 1/4" O.D.). Attach Center Post to the assembly using 3/8" Lock Nuts with 3/8" Flat Washers as shown.(NOTE: Center Post provided is for a 6' deck height and 30" below safety surfacing. For lower deck heights remove material as needed)
- Attach all six Deck Clamps to Upright Posts with the boss pointing toward the center of the hex-deck. Tighten each clamp slightly using 3/8" x 1-1/2" Hex-Pinned Tamper-Resistant Bolts and 3/8" Heavy Hex Nuts. Do not install Drive Rivet.
- Place the decks so that each corner bolt fits on a clamp hole, and fasten using 3/8" Barrel Nuts at each corner. Do not tighten fasteners.

MODEL NO. 60114 Hexagon Deck

5. Using a level, and holding one clamp as a constant, adjust the other five clamps so that the deck is completely level.
6. At this point, if you have more decks to attach, lay each succeeding deck on the ground against the previous deck's two posts, and mark the missing footings to be dug. Continue attaching decks in this manner.
7. When all decks are completed and correct, pour concrete footings within 4" to the top and taper away from support posts to allow water drainage. Allow to cure at least 48 hours before use.
8. When the assembly is finished and satisfactory, install Drive Rivets in all clamps to ensure clamps cannot slide down posts. See Deck Clamp subassembly sheet. **It is very important that all Drive Rivets be installed prior to allowing use of the equipment, as clamps are not designed to support substantial weight without them.** Eliminate sharp points and sharp edges (burring) on installed hardware like bolts, nuts, etc. Install resilient surfacing material within the *use zone* of play structure in accordance with ASTM specifications F1292 appropriate for the fall height of each structure. Refer to the *Safety Guidelines*.

MAINTENANCE PROCEDURE:

Periodically check hardware for tightness, and tighten as necessary. Always check all parts for breakage or wear, and immediately put equipment out of service until any faulty parts are repaired or replaced. Check all decks for Plastisol-coating peeling and touch-up with Plastisol if necessary. Check for holes on deck, clean if necessary. Check periodically resilient surfacing for appropriate depth and remove extraneous materials that could cause injury, infection, or disease. Maintain detailed installation, inspection, maintenance, and repair records for each public-use playground equipment.

MODEL NO. 60114 Hexagon Deck

PLAN VIEW

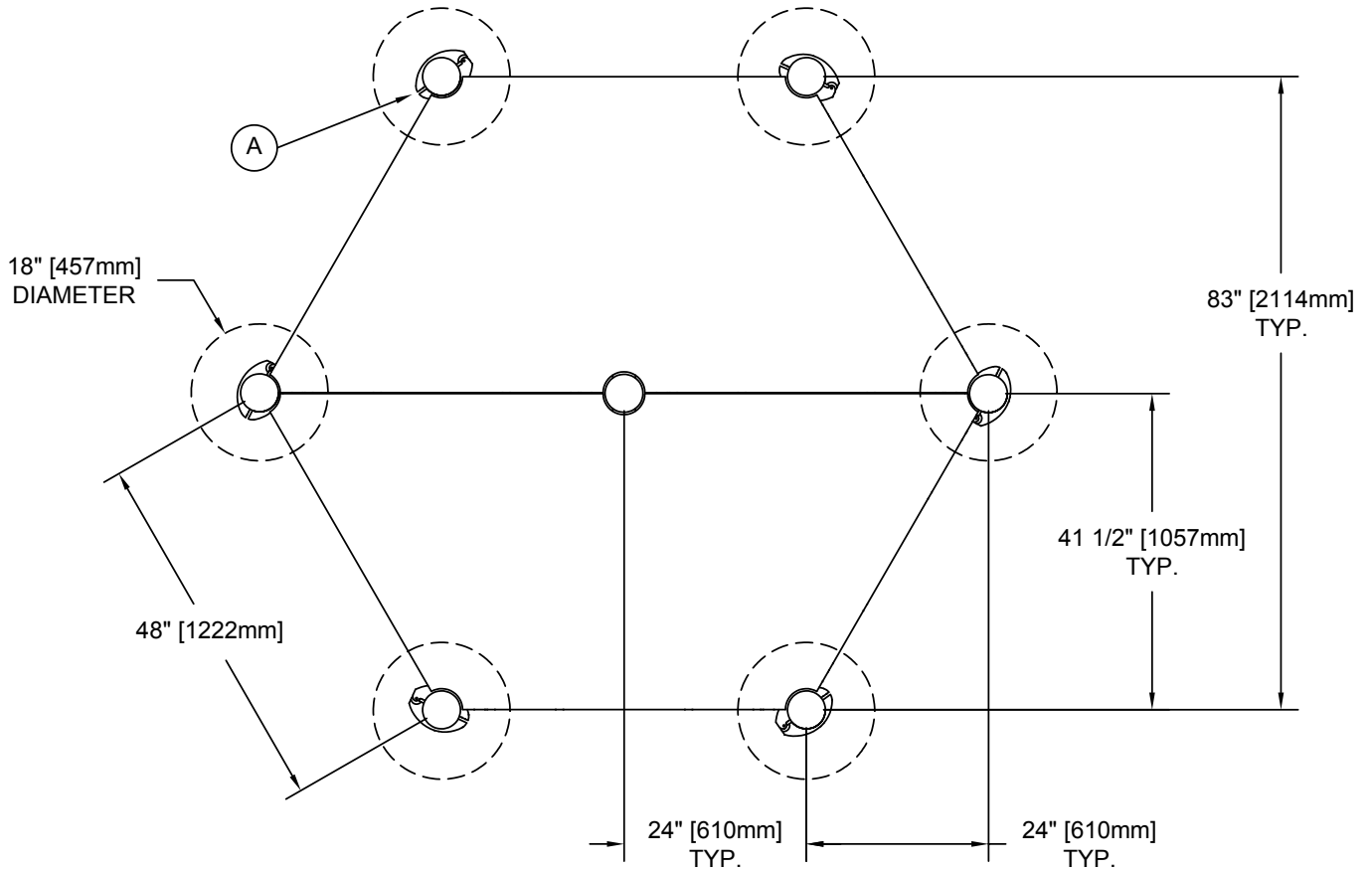

DETAIL 'A'

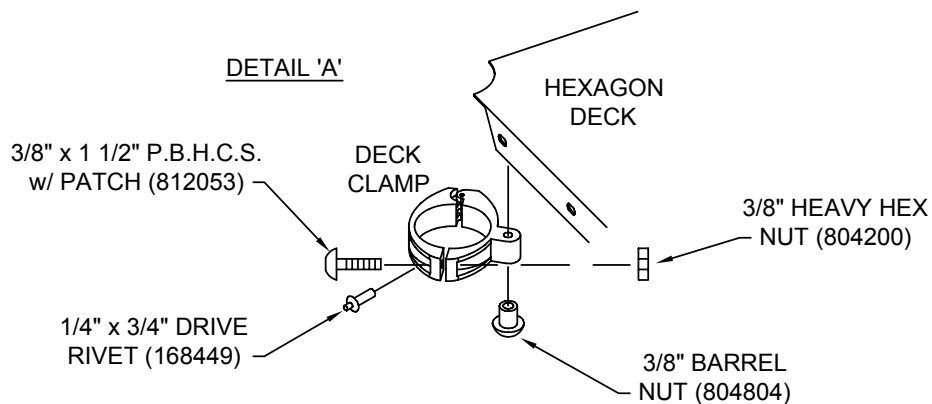

MODEL NO. 60114 Hexagon Deck

ISOMETRIC VIEW

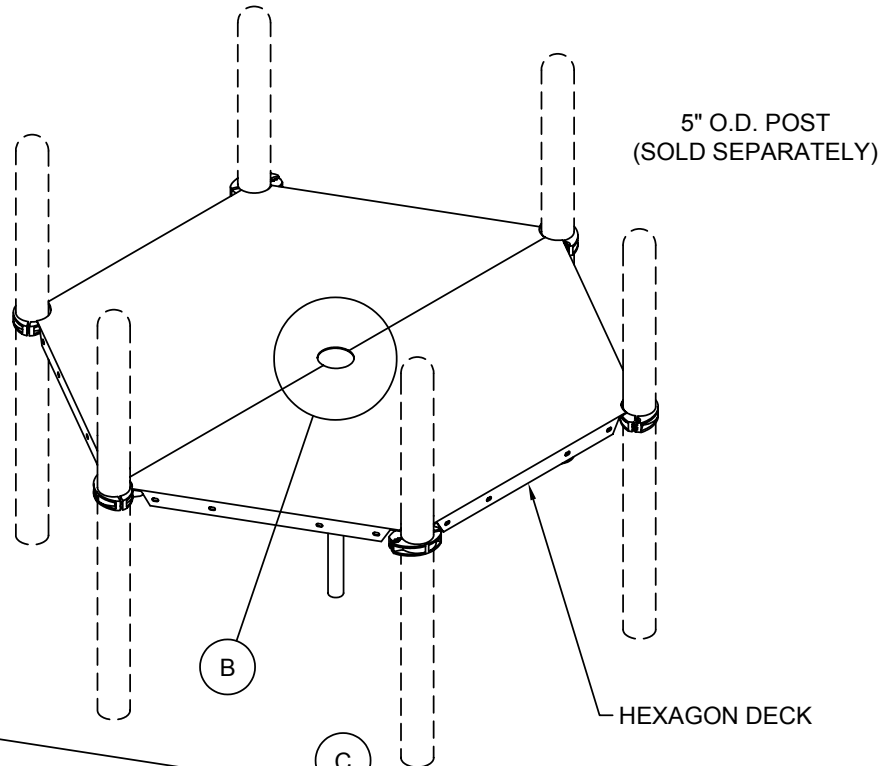

DETAIL 'B'

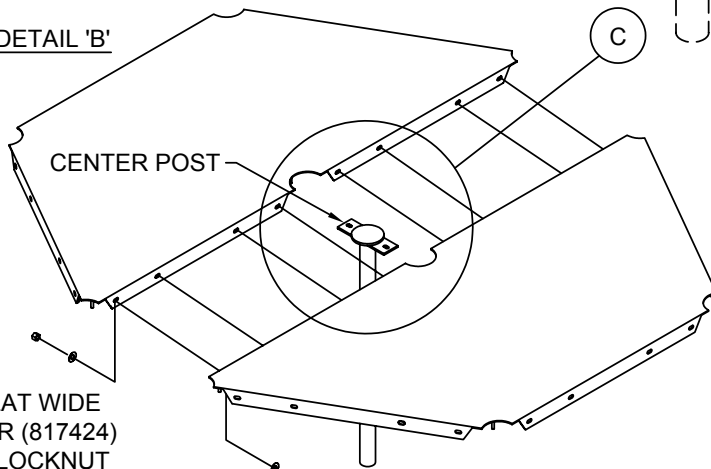

3/8" FLAT WIDE
WASHER (817424)
w/ 3/8" LOCKNUT
(804353)

3/8" x 1 1/4" P.B.H.C.S.
w/ PATCH (812051) w/
3/8" FLAT WASHER
(817410)

DETAIL 'C'

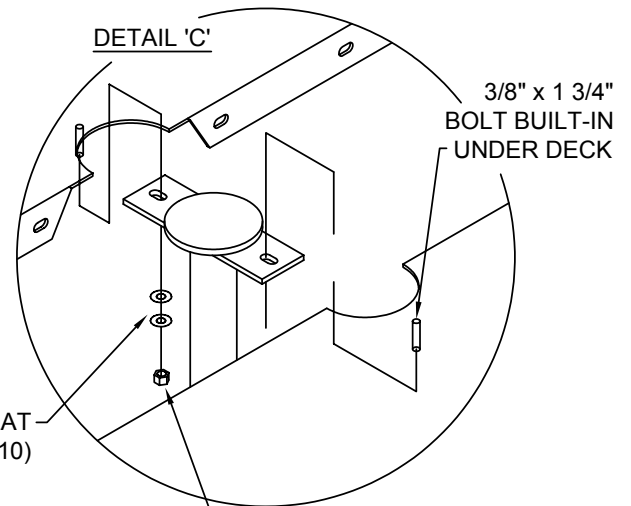

3/8" FLAT
WASHER (817410)

3/8" LOCKNUT
(804353)