

MODEL NO. 60118 Wild Swinger

PARTS LIST

DESCRIPTION	No. REQ'D	PART NUMBER
Wild Swinger	1	302959
Hardware Complete	1	302909
5" O.D. Half Clamp	4	301001*
5" O.D. Oscillating Bracket	2	301112*
Rubber Rod	8	302908*
1/4" x 3/4" Drive Rivet	4	168449*
3/8" Flat Washer	16	817410*
3/8" Lock Nut	8	804353*
3/8" x 1 1/2" P.B.H.C.S. w/ Patch	8	812053*

**Unless Otherwise Specified, All Units of Measure are Each
*Included in Hardware**

Warning: Small parts and hardware items may present a potential choking hazard. Promptly remove all unused parts from play area. Any bolt end protruding more than two full threads beyond the face of the nut causes risk of clothing entanglement. Promptly cut-off flush, file smooth, and treat to prevent corrosion.

Note: Peen Tee-Nuts and Flatwashers to match radius of pipe after assembly is complete.

SPECIFICATIONS:

Half Clamps are cast from a 356 high-strength aluminum alloy and coated with a baked on polyester powder-coated finish. Wild Swing Frame is made of 3-1/2" O.D. 11-gauge galvanized steel tubing. 1" O.D. 14-gauge galvanized steel loops (handles) are stainless steel welded to beam. A 3/16" thick plate and a 1 3/4" 11 Ga. Square tubing 3 1/2" long, is stainless steel welded at each end of beam for oscillating bracket attachment. Oscillating Brackets are made of 3" x 3" x 0.125" wall thickness square tubing with a 7-gauge half clamp to fit 5" O.D. posts. Brackets are polyester powder-coated. "Rubber Rods" are made of Butyl with diameter of 0.938". All metal parts are polyester powder-coated after fabrication.

All hardware is stainless steel.

Weight: 59 lb. / 26.8 kg.

INSTALLATION INSTRUCTIONS:

1. Locate, measure and dig footings for posts. Refer to your assembly drawing.
2. Set Posts into the excavated footings according to the footing diagram. Use a brick or other blocking device (not supplied by Park Structure) at the bottom of each post to prevent them from sinking into the earth during plumbing and leveling.
3. Insert end of Wild Swinger Beam into the chamber of the housing bracket along with Rubber Rods as shown in the assembly diagram. Then attach the assembly to posts using the supplied 3/8" x 1-1/2" P.B.H.C.S. with Patch with 3/8" Flat Washers and 3/8" Lock Nuts with 3/8" Flat Washers at the height indicated as shown in the assembly diagram.
4. Once the entire play structure is assembled, and all posts have been properly braced, re-check plumb and level. Pour concrete per the typical footing diagram only when all positions are correct. Be sure to taper concrete around post as shown to facilitate good water drainage.
5. When structure is finished and satisfactory, tighten all fasteners and install Drive Rivets in all clamps to ensure clamps cannot slide down posts. See pipe Clamp sub-assembly sheet. **It is very important that all Drive Rivets be installed prior to allowing use of the equipment, as clamps are not designed to support substantial weight without them.** Install resilient surfacing material within the use zone of play structure in accordance with ASTM specifications F1292 appropriate for the fall height of each structure. Refer to the Safety Guidelines. Also eliminate sharp points and sharp edges (burring) on installed hardware like bolts, nuts, etc.

MODEL NO. 60118 Wild Swinger

MAINTENANCE PROCEDURE:

Periodically check hardware for tightness, and tighten as necessary. Always check all parts for breakage or wear, and immediately put equipment out of service until any faulty parts found are repaired or replaced. Check for rust, paint loss and touch-up if necessary with paint. Check for welded areas and verify integrity. Check periodically resilient surfacing for appropriate depth and remove extraneous materials that could cause injury, infection, or disease. Maintain detailed installation, inspection, maintenance, and repair records for each public-use playground equipment.

MODEL NO. 60118 Wild Swinger

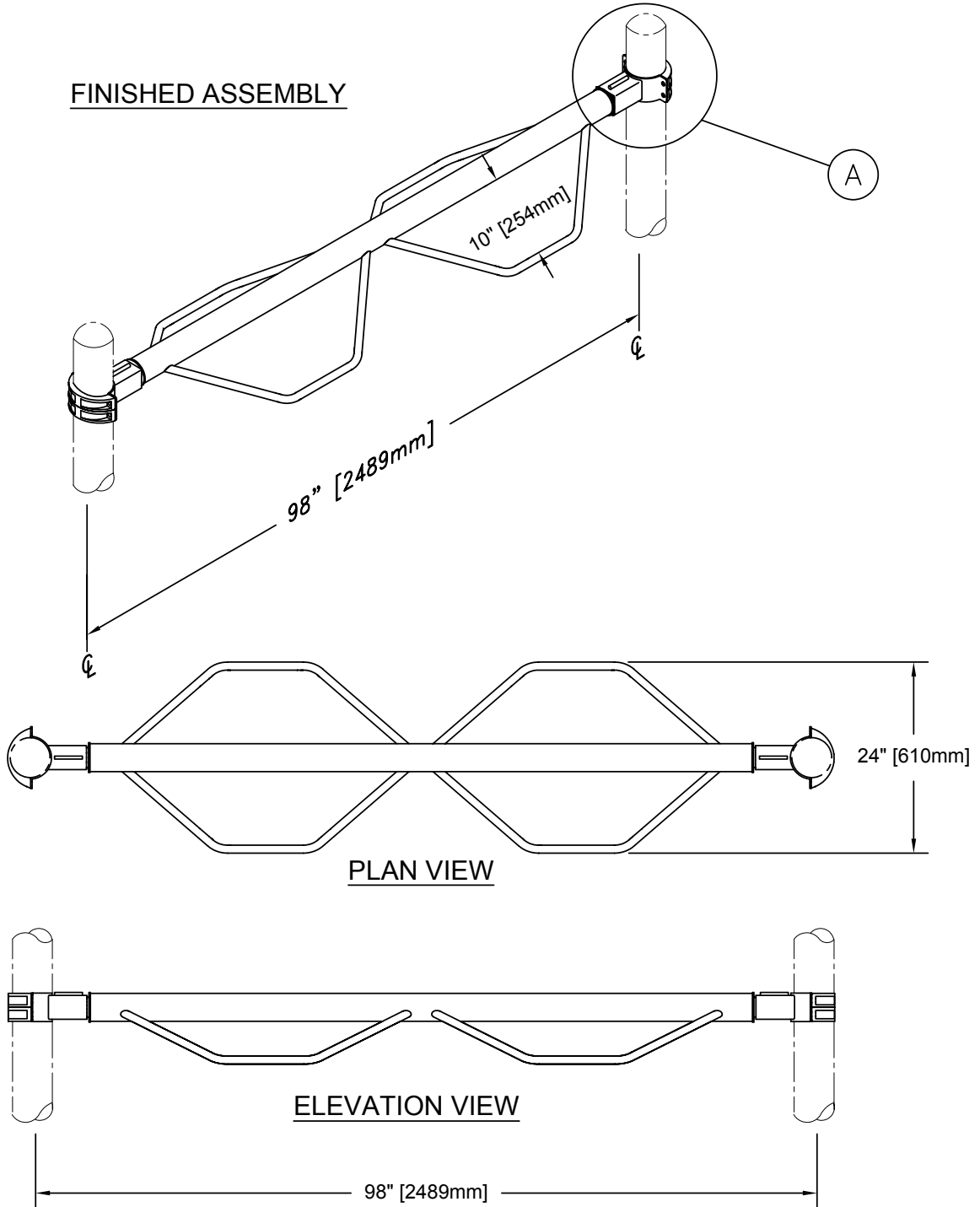

MODEL NO. 60118 Wild Swinger

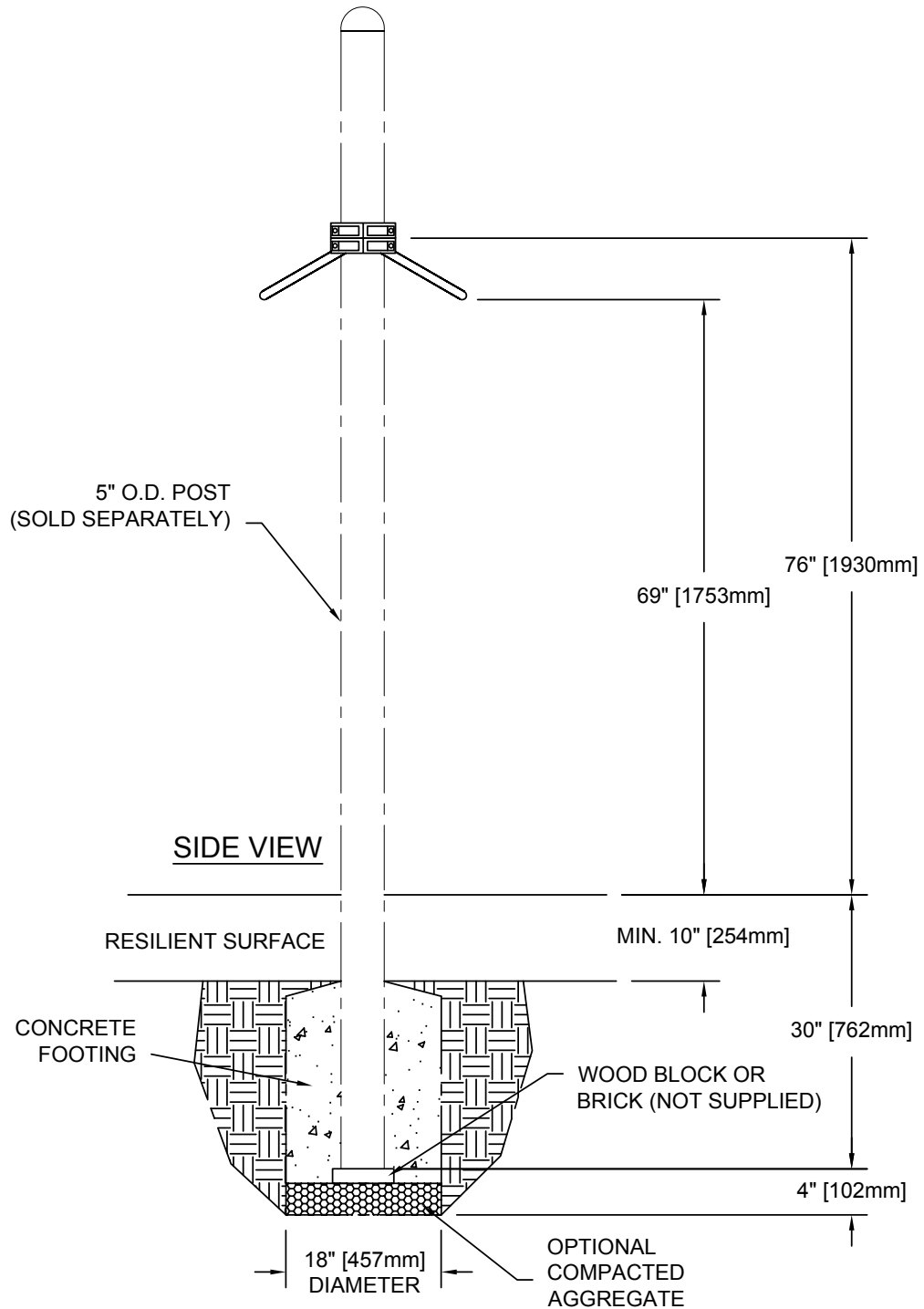

MODEL NO. 60118 Wild Swinger

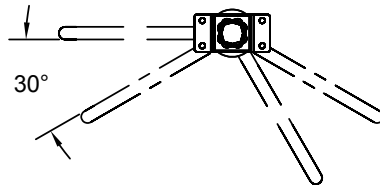

ROCKING
ANGLE

NOTE: OSCILLATING BRACKET SHOULD BE TURNED SO THAT RIB IS FACING UPWARD AS SHOWN.

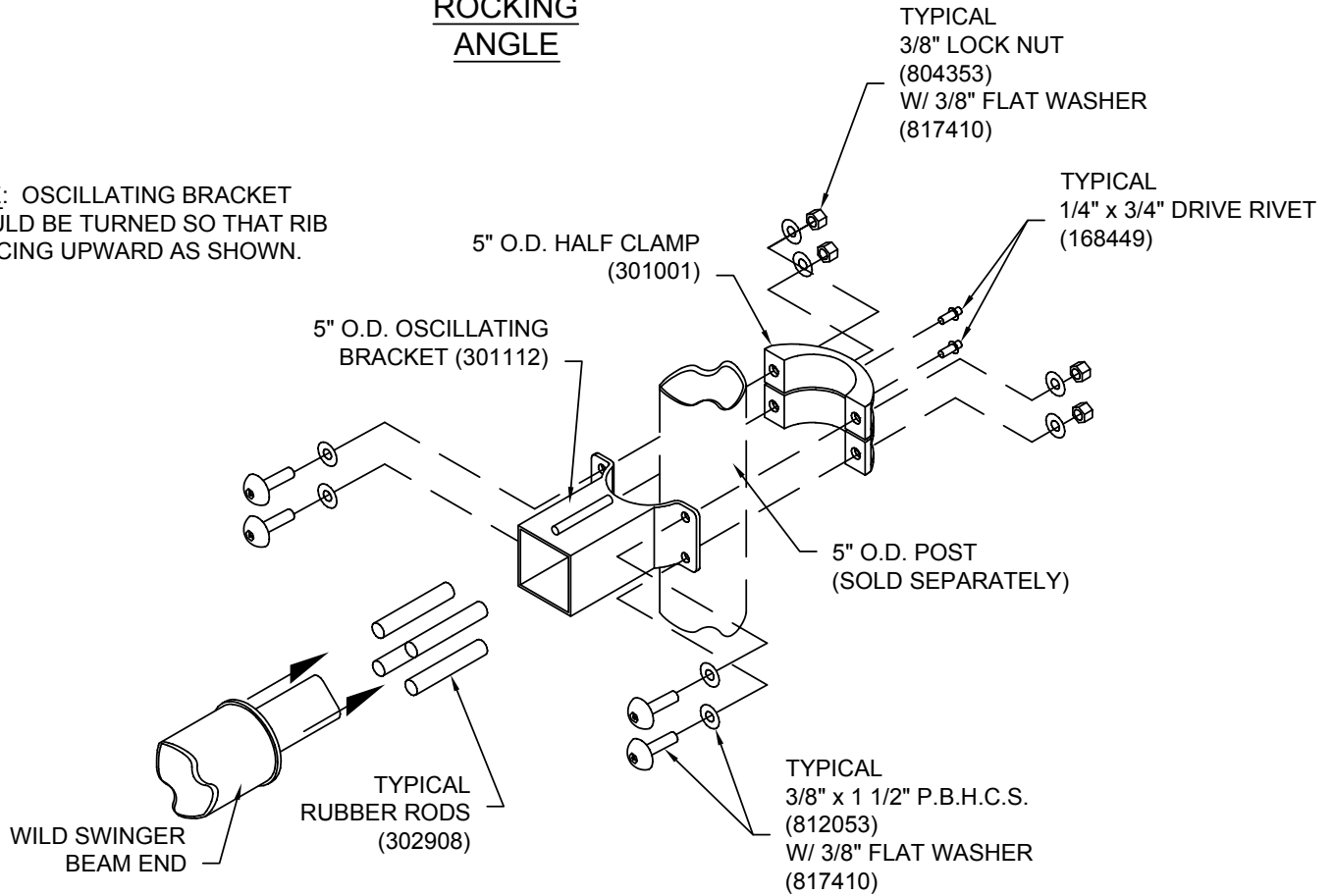

DETAIL 'A'