

MODEL NO. 60126 Two Flush Mounted Square Decks

PARTS LIST

| DESCRIPTION | No. REQ'D | PART NUMBER |
|-----------------------------------|--------------|----------------|
| Square Deck Platform | 2 | 300213 |
| Hardware Complete | 1 | 302987 |
| 5" O.D. Deck Clamp | 6 | 301989* |
| 1/4" x 3/4" Drive Rivet | 6 | 168449* |
| 3/8" Lock Nut | 4 | 804353* |
| 3/8" Barrel Nut | 6 | 804804* |
| 3/8" Heavy Hex Nut | 6 | 804200* |
| 3/8" (1 1/4" O.D.) Flat Washer | 8 | 817424* |
| 3/8" x 1" P.B.H.C.S. w/ Patch | 4 | 812050* |
| 3/8" x 1 1/2" P.B.H.C.S. w/ Patch | 6 | 812053* |

**Unless Otherwise Specified, All Units of Measure are Each
*Included in Hardware**

Warning: Small parts and hardware items may present a potential choking hazard. Promptly remove all unused parts from play area.

SPECIFICATIONS:

Clamps are cast from a 356 high-strength aluminum alloy with a baked on polyester powder-coated paint finish. Square Decks are fabricated from pre-punched steel sheet 11-gauge, with built-in 3/8" x 1-3/4" zinc-plated bolts on each corner of the deck to be attached to a deck clamp. Each deck uses 11-gauge thick lower steel flat bar supports welded to the deck to increase strength. After welding, entire deck is Plastisol coated with a thickness of 50 to 80 mils on top wear surface. Average perforation size is 0.35" diameter after coating.

All hardware is stainless steel with exception of built-in deck bolts.

Weight: 188 lb. / 85.5 kg

INSTALLATION INSTRUCTIONS:

Note: Prevent bolts end projecting (protruding) beyond the face of the nuts no more than two full threads.

1. Place Upright Posts in dug holes at appropriate height per Upright Post installation instructions. Get the height required for the deck from the Plan View Diagram; use a felt-tip marker to mark the top of the Deck Clamp on all four posts.

HINT: If this are the first decks of the structure, locate and concrete one post only (preferably the most shared post, if this decks are part of a multi deck group), ensuring it is plumb and at the right height. After it has had a chance to set, place one corner of the deck against the post and mark the location of the adjacent post. Concrete the second post. Continue this procedure for all four posts while leaving the deck on the ground. The deck had been used as its own template, and the deck is now easily attached as two of its posts are already in place.

2. Attached the two decks together using 3/8" x 1" P.B.H.C.S. with Patch with 3/8" (1 1/4" O.D.) flat washers and 3/8" lock nuts as shown in the assembly drawing.
3. Attach all six Deck Clamps with the boss pointing towards the center of the deck. Tighten each clamp slightly using 3/8" x 1-1/2" P.B.H.C.S. with Patch and 3/8" Heavy Hex Nut.

Note: Decks Clamps at junction (middle) should be attached to opposite decks to distribute load. Extra bolts at junction should be removed to eliminate protrusions.

MODEL NO. 60126 Two Flush Mounted Square Decks

4. Place the deck so that each corner bolt fits on a clamp hole, and fasten using a 3/8" Barrel Nut at each corner. **Do not tighten.** Plumb and level all four posts and brace in position.
5. Using a level, and holding one clamp as a constant, adjust the other six clamps so that the deck is completely level.
6. At this point, if you have more decks to attach, lay each succeeding deck on the ground against the previous deck's two posts, and mark the missing two footings to be dug. Continue attaching decks in this manner.
7. When all decks are complete and correct, pour concrete footings within 4" to the top and taper away from support posts to allow water drainage. Allow curing at least 48 hours before use.
8. When the structure is finished and satisfactory, install Drive Rivets in all clamps to ensure clamps cannot slide down posts. See Pipe Clamps sub-assembly sheet. **It is very important that all Drive Rivets be installed prior to allowing use of the equipment, as clamps are not designed to support substantial weight without them.** Eliminate sharp points and sharp edges (burring) on installed hardware like bolts, nuts, etc. Install resilient surfacing material within the use zone of play structure in accordance with ASTM specifications F1292 appropriate for the fall height of each structure. Refer to the Safety Guidelines.

MAINTENANCE PROCEDURE:

Periodically check hardware for tightness, and tighten as necessary. Always check all parts for breakage or wear, and immediately put equipment out of service until any faulty parts found are repaired or replaced. Also Check all metal parts for rust, paint loss and touch-up if necessary with paint. Check for welded areas and verify integrity. Check Plastisol-coating for bare spots and touch-up with Plastisol if necessary. Clear any trapped debris from deck perforations. Check periodically resilient surfacing for appropriate depth and remove extraneous materials that could cause injury, infection, or disease. Maintain detailed installation, inspection, maintenance, and repair records for each public-use playground equipment.

MODEL NO. 60126 Two Flush Mounted Square Decks

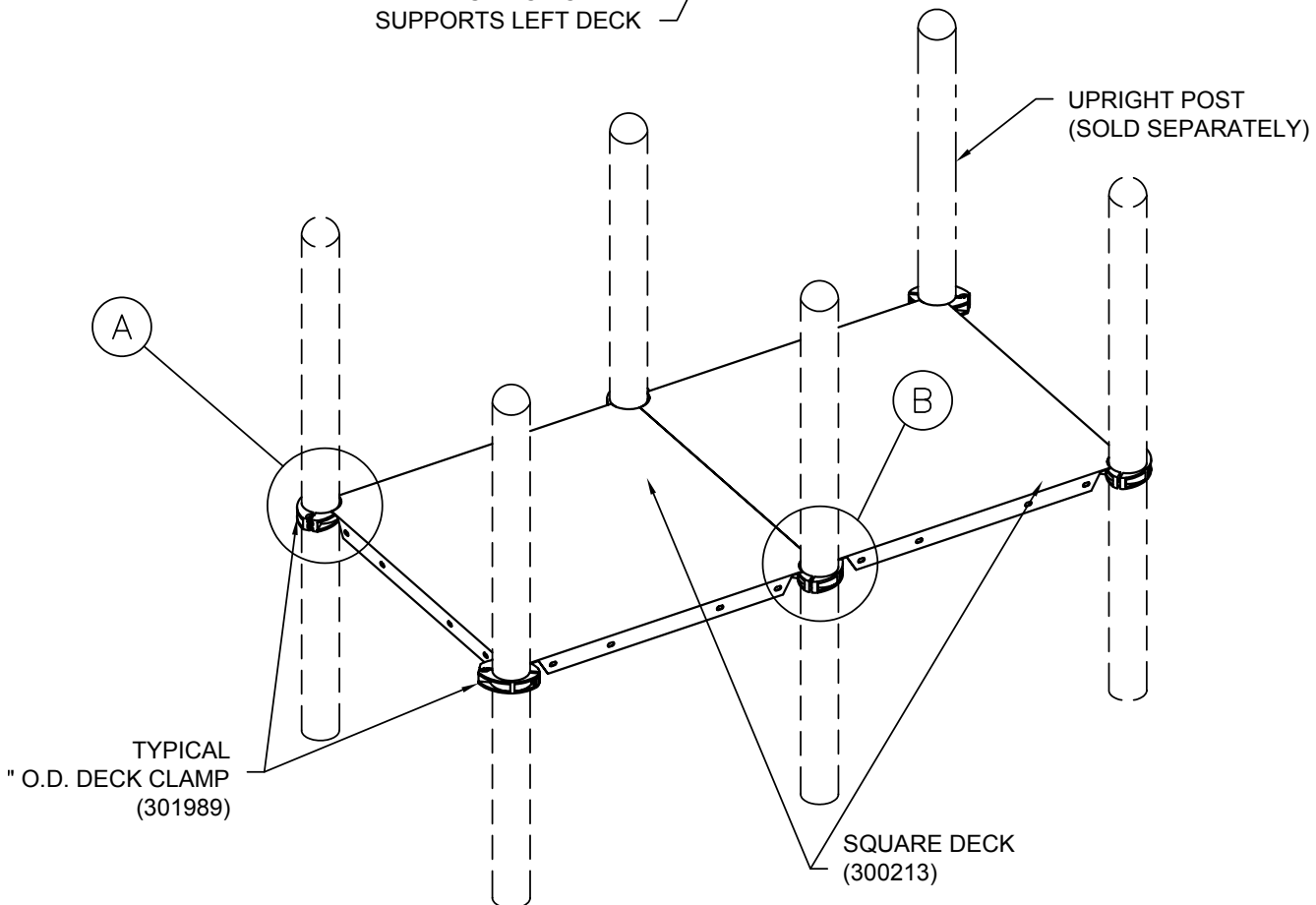
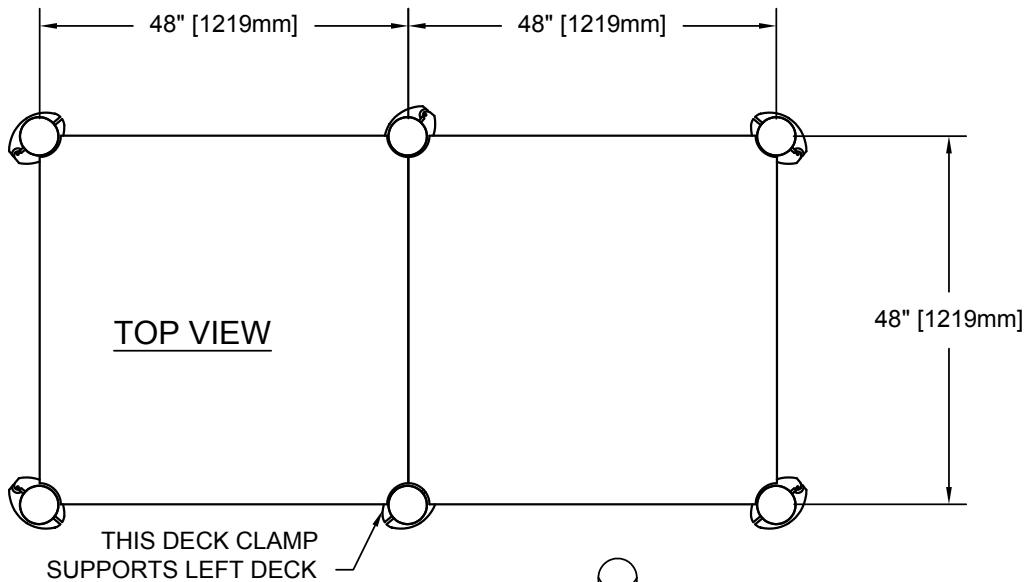

FINISHED ASSEMBLY

MODEL NO. 60126 Two Flush Mounted Square Decks

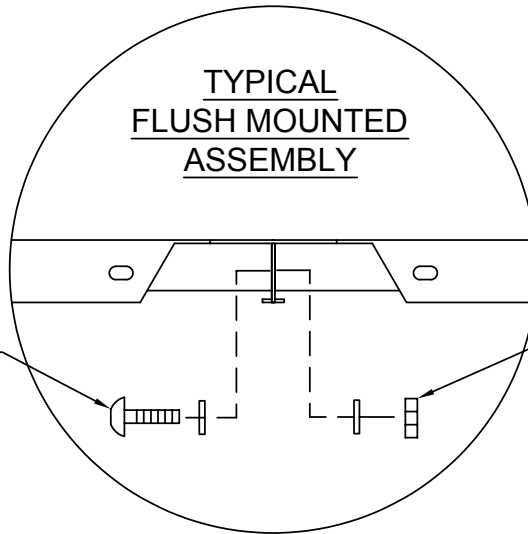

TYPICAL
3/8" x 1" P.B.H.C.S.
(812050)
W/ 3/8" (1 1/4" O.D.) FLAT WASHER
(817424)

TYPICAL
3/8" LOCK NUT (804353)
W/ 3/8" (1 1/4" O.D.) FLAT WASHER
(817424)

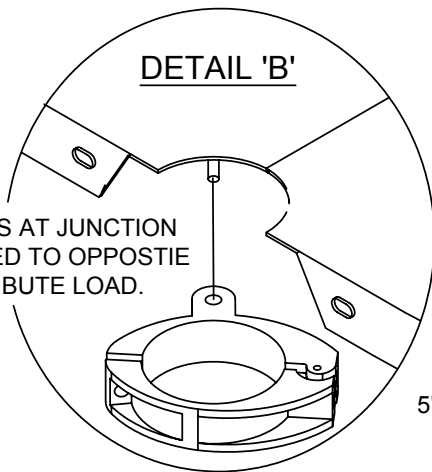

NOTE: DECK CLAMPS AT JUNCTION
SHOULD BE ATTACHED TO OPPOSITE
DECKS TO DISTRIBUTE LOAD.

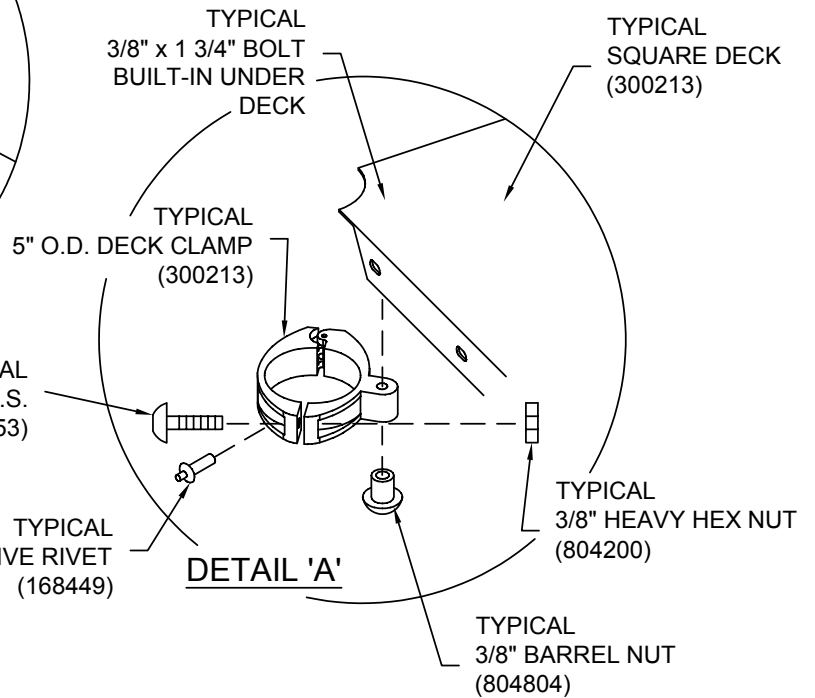

TYPICAL
3/8" x 1 3/4" BOLT
BUILT-IN UNDER
DECK

TYPICAL
SQUARE DECK
(300213)

TYPICAL
5" O.D. DECK CLAMP
(300213)

TYPICAL
3/8" x 1 1/2" P.B.H.C.S.
(812053)

TYPICAL
3/8" HEAVY HEX NUT
(804200)

TYPICAL
1/4" x 3/4" DRIVE RIVET
(168449)

TYPICAL
3/8" BARREL NUT
(804804)