

## MODEL NO. 60143 Single Step Transfer

### PARTS LIST

DESCRIPTION	No. REQ'D	PART NUMBER
Single Step Transfer	1	300067
U-Handle	1	300652
Support Leg	2	300752
<b>Hardware Complete</b>	1	303122
5" O.D. Pipe Clamp	2	302030*
1/4" x 3/4" Drive Rivet	4	168449*
3/8" Flat Washer	2	817410*
3/8" Heavy Hex Nut	2	804200*
3/8" X 1 1/2" P.B.H.C.S. w/ Patch	2	812053*
3/8" X 1" P.B.H.C.S. w/ Patch	2	812050*
3/8" Lock Nut	2	804353*
3/8" X 3/8" Set Screw	2	811549*
3/8" Wide Flat Washer (1 1/4" O.D.)	6	817424*
3/8" Lock Washer	4	817334*
3/8" X 3/4" P.B.H.C.S. w/ Patch	4	812052*
3/8" Tee Nut	4	804556*

*Unless Otherwise Specified, All Units of Measure are Each  
\* Included in Hardware*

**Warning:** Small parts and hardware items may present a potential choking hazard. Promptly remove all unused parts from play area. Any bolt end protruding more than two full threads beyond the face of the nut causes risk of clothing entanglement. Promptly cut-off flush, file smooth, and treat to prevent corrosion.

**Note:** Peen Tee-Nuts and Flatwashers to match radius of pipe after assembly is complete

**Note:** Loctite (supplied by others) should be used on any non-patch hardware.

#### SPECIFICATIONS:

Clamps are cast from an aluminum alloy with a baked on polyester powder-coated paint finish. Step is fabricated from pre-punched steel sheet 11-gauge. After fabrication, entire Step is Plastisol-coated with a thickness of 50 to 80 mils on top of wear surface. Average perforation size is 5/16" diameter after coating. U-Handle is formed from 1-5/16" O.D. 14-gauge galvanized steel tubing and polyester powder-coated. 24" Support Legs are 1-5/8" O.D. 14-gauge galvanized steel tubing with one end flattened and pre-punched for attachment.

All hardware is stainless steel.

Weight: 83 lb. / 37.7 kg

#### INSTALLATION INSTRUCTIONS:

**Note:** This Model is designed to be used with a 16" high deck.

1. Dig footing holes at appropriate locations as shown in the footing diagram. Refer to your overhead drawing for location.
2. Attach 24" Support Legs to lower end of step using 3/8" x 1" P.B.H.C.S. w/ Patch, 3/8" (1 1/4" O.D.) Flat Washers, 3/8" Lock Nuts and 3/8" Flat Washers. Position assembly in holes and match upper transfer step holes to existing 16" high deck holes and fasten using 3/8" x 3/4" P.B.H.C.S. w/ Patch with 3/8" Lockwasher, 3/8" Wide Flat Washers to 3/8" Tee Nuts as shown in diagram.
3. Attach U-handle as shown, so that top of the U-handle is 38" above the surface of the existing deck. Refer to Pipe Clamp sub-assembly sheet for detail or Detail "A".
4. Plumb and level the entire assembly and brace in position. Tighten pipe clamp fasteners.
5. Pour concrete footings within 4" to the top and taper way from support posts to allow water drainage. Allow to cure at least 48 hours before use.

## MODEL NO. 60143 Single Step Transfer

6. When the structure is finished and satisfactory, install Drive Rivets to all Clamps to ensure clamps cannot slide down posts. See Pipe Clamps sub-assembly sheet. **It is very important that all Drive Rivets be installed prior to allowing use of equipment, as clamps are not designed to support substantial weight without them.** Also eliminate sharp points and sharp edges (burring) on installed hardware like bolts, nuts, etc. Install resilient surfacing material within the *use zone* of play structure in accordance with ASTM specifications F1292 appropriate for the fall height of each structure. Refer to the *Safety Guidelines*.

### MAINTENANCE PROCEDURE:

Periodically check hardware for tightness, and tighten as necessary. Always check all parts for breakage or wear, and immediately put equipment out of service until any faulty parts are repaired or replaced. Check all decks for Plastisol-coating peeling and touch-up with Plastisol if necessary. Check for holes on deck, clean if necessary. Check periodically resilient surfacing for appropriate depth and remove extraneous materials that could cause injury, infection, or disease. Maintain detailed installation, inspection, maintenance, and repair records for each public-use playground equipment.

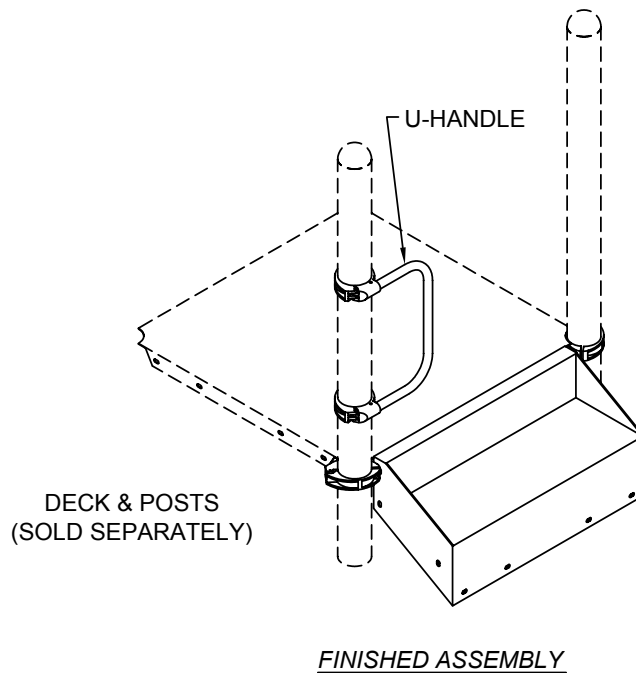

## MODEL NO. 60143 Single Step Transfer

