

## MODEL NO. 60145 Trapeze Rings - 4'

### PARTS LIST

DESCRIPTION	No. REQ'D	PART NUMBER
5" O.D. Pipe	1	302871
<b>Hardware Complete</b>	1	303127
Trapeze Ring	2	301756*
Large Clamp	2	302956*
5" O.D. Swivel Clamp w/bushing	2	302572*
Galv. Chain w/ 'S'-Hook	2	301725*
Swing Hanger Pendulum	2	301168*
1/4" x 3/4" Drive Rivet	6	168449*
3/8" Heavy Hex Nut	6	804200*
3/8" x 1 1/2" P.B.H.C.S. w/Patch	6	812053*
3/8" Set Screw	4	811549*
5/16" Lock Nut	2	804359*
3/8" x 2 1/2" Shoulder Bolt	2	802731*

*Unless Otherwise Specified, All Units of Measure are Each  
\* Included in Hardware*

**Warning: Small parts and hardware items may present a potential choking hazard. Promptly remove all unused parts from play area.**

#### **SPECIFICATIONS:**

Clamps are cast from a 356 high-strength aluminum alloy with a baked on polyester powder-coated finish.

Swivel Clamps are fitted with a pressed oil-impregnated bronze bushing and attached using the Shoulder Bolt to a hot-dip galvanized 5/16" steel Pendulum for smooth movement. Trapeze Beams are 5" O.D. 11-gauge galvanized steel tubing. Trapeze Rings are Cast Aluminum. All parts have a baked on polyester powder-coated finish after fabrication. Proof Coil Chains are 1/4" Grade 30 ISO with a maximum loading of 1250 lbs. each.

All hardware is stainless steel.

Weight: 50 lb. / 22.7 kg

#### **INSTALLATION INSTRUCTIONS:**

1. Located the Upright Posts intended to receive the Trapeze Rings by referring to your overhead drawing. They should be spaced 4' apart lengthwise, and 4' apart widthwise.
  2. Referring to the diagram, mark the two Upright Posts approximately 84" above finished ground level. (Adjust height up or down to suit age group, if necessary).
  3. Attach Two Large Clamps to ends of each 41" beam, and only slightly tighten the fasteners. Refer to detail 'A'.
  4. Attach Swivel Clamps to two 41" Beam, spacing them 16" apart. Fasten the Swing Hanger Pendulums and chains as shown in the assembly diagram. NOTE: Fully tighten Shoulder Bolts, but be sure Swing Hanger is allowed to swivel freely. Non-movement of the Swing Hanger may cause premature wear against the chain link, resulting in failure and possible injury to the user.
- Attach the assembled 41" Trapeze Beam to Upright Posts as shown in detail 'A' at the marks. Level and fully tighten all Clamp fasteners. Do not attach Trapeze Rings until resilient surfacing has been installed.
- 5.

## MODEL NO. 60145 Trapeze Rings - 4'

6. When the structure is finished and satisfactory, install Drive Rivets in all clamps to ensure clamps can not slide down posts. See Clamps sub-assembly sheet. ***It is very important that all Drive Rivets be installed prior to allowing use of equipment, as clamps are not designed to support substantial weight without them.*** Also eliminate sharp points and sharp edges (burring) on installed hardware like bolts, nuts, etc. Install resilient surfacing material within the use zone of play structure in accordance with ASTM specifications F1292 appropriate for the fall height of each structure. Refer to the Safety Guidelines.
7. Referring to Detail 'B', attach Trapeze Rings to each hanging 'S' hook. Tighten all Swivel Clamp fasteners before allow use of equipment. Be sure to fully crimp shut all 'S' hooks as per specification ASTM F 1487 section 6.3 for Entanglement.

### **MAINTENANCE PROCEDURE:**

Periodically check hardware for tightness, and tighten as necessary. Always check all parts for crack, breakage or wear, and immediately put equipment out of service until any faulty parts found are repaired or replaced. Check for rust, paint loss and touch up if necessary. Check for welded areas and verify integrity. Check Plastisol-coating for bare spots and touch-up with Plastisol if necessary. Check 'S' hooks at both ends and all connection points for wear. Check all moving parts such as bushings, hangers and chains for wear. Check opening on 'S' Hooks for entanglement as specified by ASTM F1487-01 Section 6.3. Check periodically resilient surfacing for appropriate depth and remove extraneous materials that could cause injury, infection, or disease. Maintain detailed installation, inspection, maintenance, and repair records for each public-use playground equipment.

## MODEL NO. 60145 Trapeze Rings - 4'

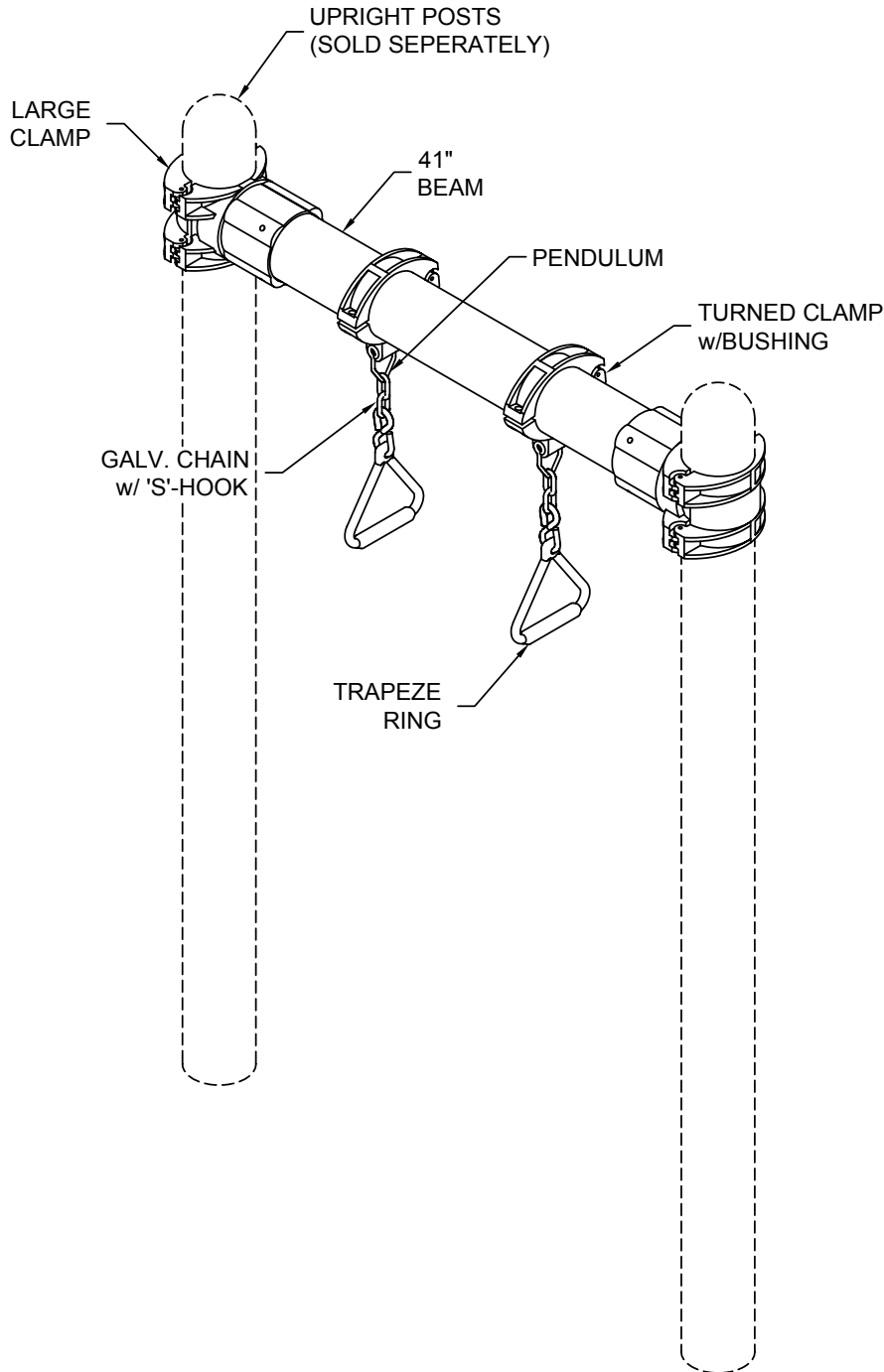

FINISHED ASSEMBLY

## MODEL NO. 60145 Trapeze Rings - 4'

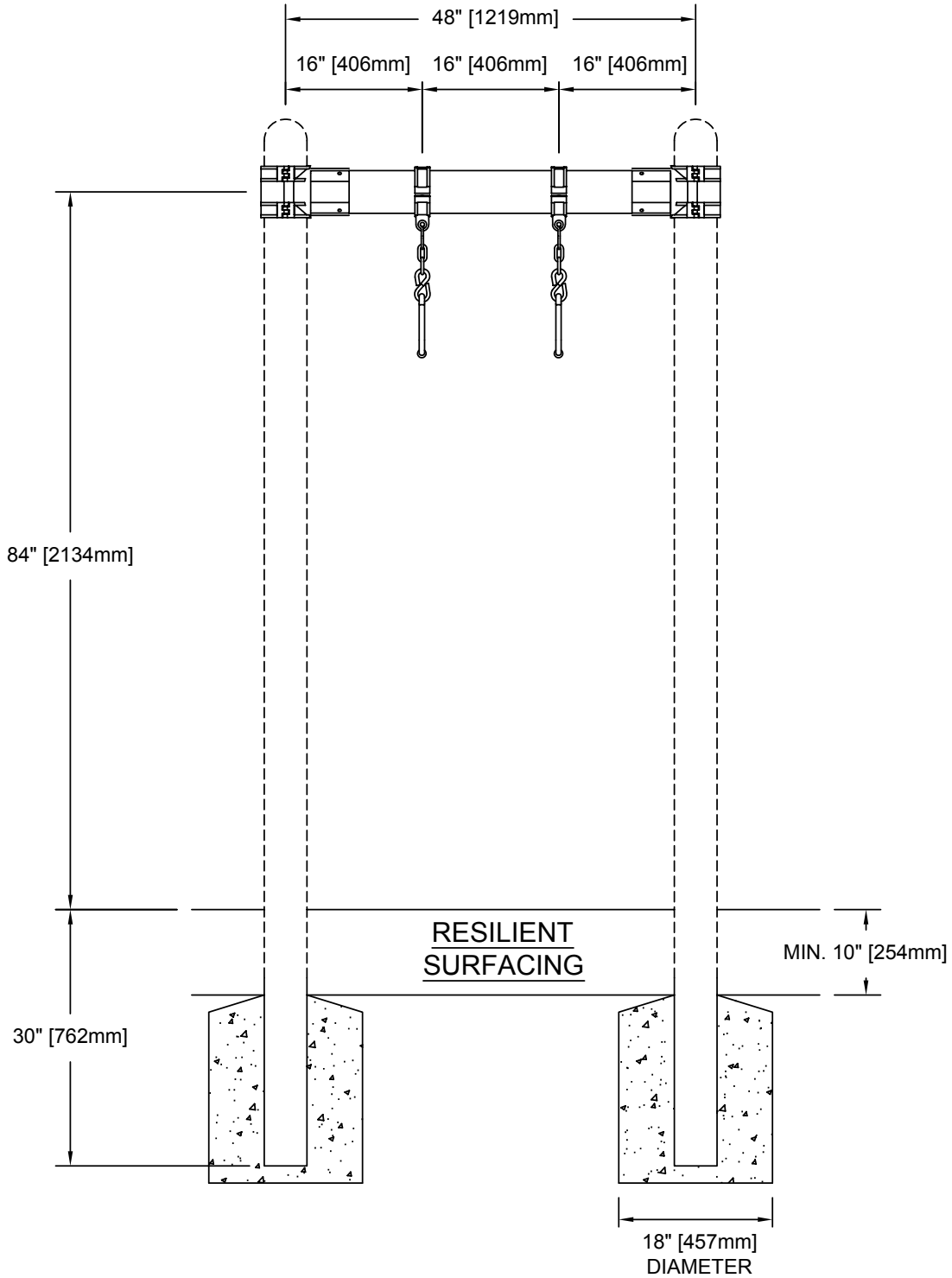

ELEVATION VIEW

## MODEL NO. 60145 Trapeze Rings - 4'

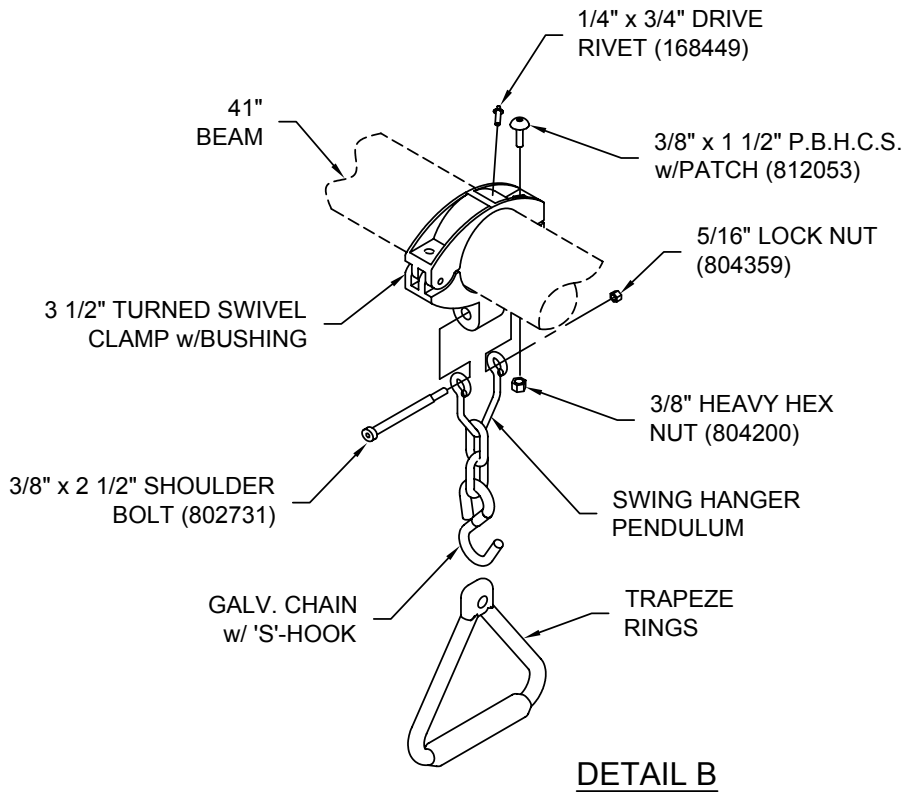
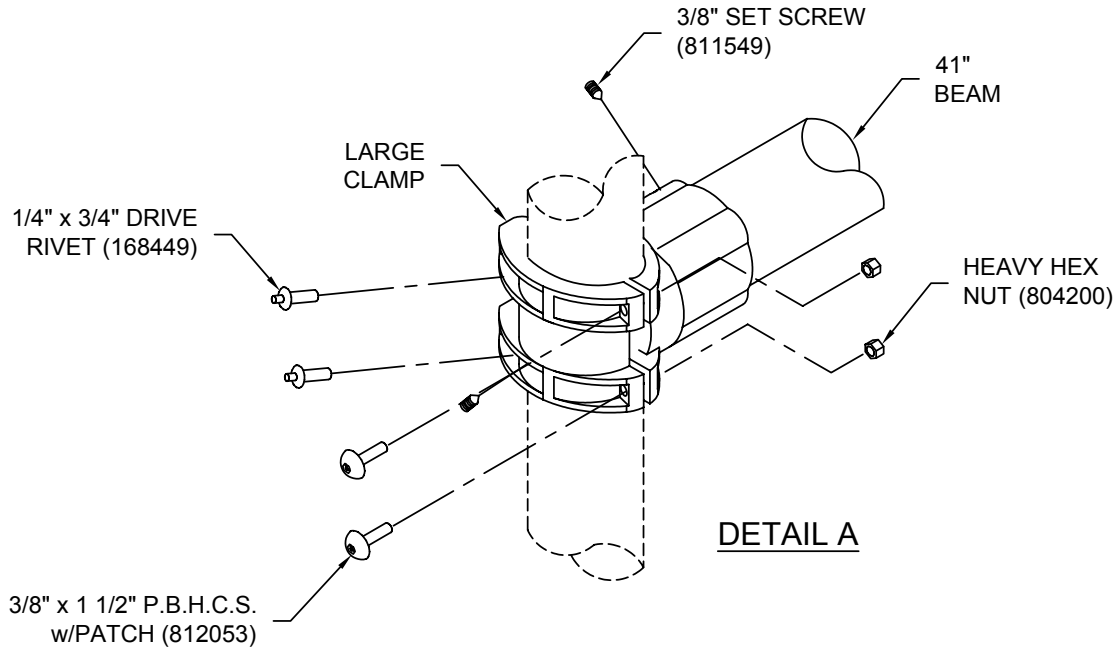

### TRAPEZE RINGS ASSEMBLY