

MODEL NO. 60147 Chain Climber (2'8", 3'4", and 4' Deck)

PARTS LIST

DESCRIPTION	No. REQ'D	PART NUMBER
U-Handle	2	300652
Chain Climber Lower Pipe	1	300684
Chain Climber Upper Bracket	1	300690
Chain Climber Ass'y	1	300688
Hardware Complete	1	303151
5" O.D. Pipe Clamp	4	302030*
1/4" x 3/4" Drive Rivet	8	168449*
3/8" Flat Washer	4	817410*
3/8" Heavy Hex Nut	4	804200*
3/8" X 1 1/2" P.B.H.C.S. w/ Patch	4	812053*
3/8" X 1" P.B.H.C.S. w/ Patch	4	812050*
3/8" Lock Nut	4	804353*
3/8" X 3/8" Set Screw	4	811549*
3/8" Wide Flat Washer (1 1/4" O.D.)	4	817424*

*Unless Otherwise Specified, All Units of Measure are Each
* Included in Hardware*

Warning: Small parts and hardware items may present a potential choking hazard. Promptly remove all unused parts from play area.

SPECIFICATIONS:

Clamps are cast from a 356 high-strength aluminum alloy and coated with a baked on polyester powder-coated finish.

Chain Climber Upper Bracket with loops is fabricated from 1/4" thick steel plate with loops bent from 3/8" O.D stainless steel rod and stainless steel welded to plate.

Chain Climber Lower Pipe with loops is fabricated from 1-5-16" O.D. galvanized steel tubing with loops bent from 3/8" stainless steel rod and stainless steel welded to tubing.

Chain Climber is factory-assembled using 1" O.D. galvanized steel tubes as rungs mechanically fastened to 1/4" Grade-30 ISO Proof Coil Galvanized Chain. Heavy-duty 3/8" x 3" plated "S" hooks are crimped at the end of the chain, and the entire assembly is plastisol-coated. No welds are used in this assembly.

All hardware is stainless steel.

Weight: 67 lb. / 30.5 kg

INSTALLATION INSTRUCTIONS:

1. Dig footings at locations as shown in Footing Diagram. Note that footing distances are for 2'8", 3'4", and 4' high deck.
2. Attach Chain Climber Upper Bracket to Deck outer flange using 3/8" x 1" P.B.H.C.S. w/ Patch, Flat Wide Washers, Wide Flat Washers and 3/8" Lock Nuts as shown in assembly drawing. Loops should be oriented downward. Slide "S" hooks over top of loops and stretch Chain Climber to the Ground to determine exact location for Lower Pipe supports.
3. Position Lower Pipe support in footing holes, plumb, level and brace the Pipe in position. Note that Lower Bracket must be below surfacing and should never become exposed. Pour concrete footing within 4" to the top and taper away from Posts for good water drainage. Allow curing at least 48 hours before proceeding. Note: Remove Chain Climber while curing to discourage climbing.
4. Fully fasten the Upper Bracket and attach the Chain Climber assembly to the Upper Bracket and Lower Pipe support by crimping all "S" hooks fully closed over loops. "S" hooks should be facing downward as Shown in Detail 'A'.

MODEL NO. 60147 Chain Climber (2'8", 3'4", and 4' Deck)

5. Attach U-Handles to Upright Posts using 5" O.D. Pipe Clamps. Refer to Sub-assembly sheet or Detail 'B'. Note that top of U-Handle should be 38" above Deck height and positioned 45° away from deck for easy grabbing.
6. When the structure is finished and satisfactory, install Drive Rivets in all large clamps to ensure clamps can not slide down posts. See Pipe Clamps sub-assembly sheet. ***use of equipment, as clamps are not designed to support substantial weight without them.*** Eliminate sharp points and sharp edges (burring) on installed hardware like bolts, nuts, etc. Install resilient surfacing material within the use zone of play structure in accordance with ASTM specifications F1292 appropriate for the fall height of each structure. Refer to the Safety Guidelines.

MAINTENANCE PROCEDURE:

Periodically check hardware for tightness, and tighten as necessary. Always check all parts for breakage or wear, and immediately put equipment out of service until any faulty parts are repaired or replaced. Check all decks for Plastisol-coating peeling and touch-up with Plastisol if necessary. Check for holes on deck, clean if necessary. Check periodically resilient surfacing for appropriate depth and remove extraneous materials that could cause injury, infection, or disease. Maintain detailed installation, inspection, maintenance, and repair records for each public-use playground equipment.

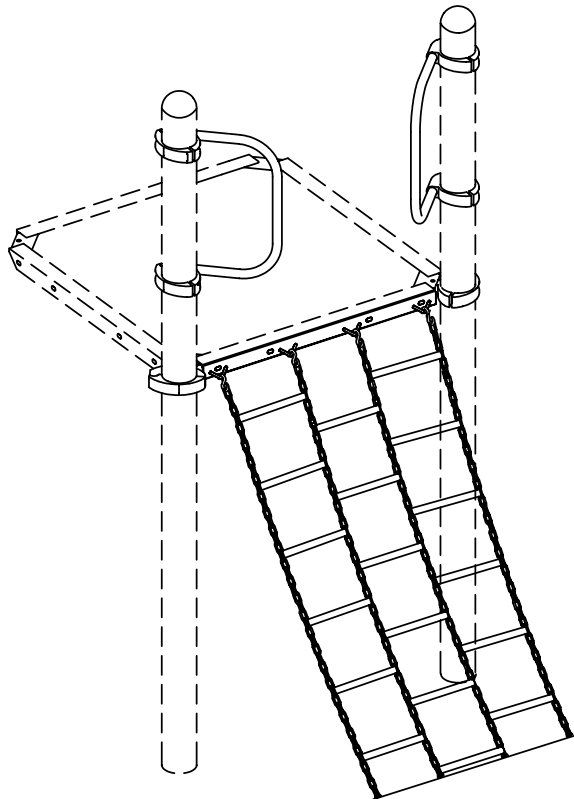

FINISHED ASSEMBLY

MODEL NO. 60147 Chain Climber (2'8", 3'4", and 4' Deck)

DETAIL 'B'

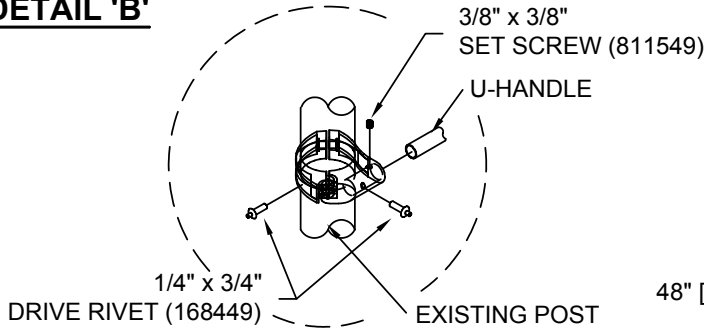

NOTE: FIELD DRILL & LOCATE DRIVE RIVET AS SHOWN

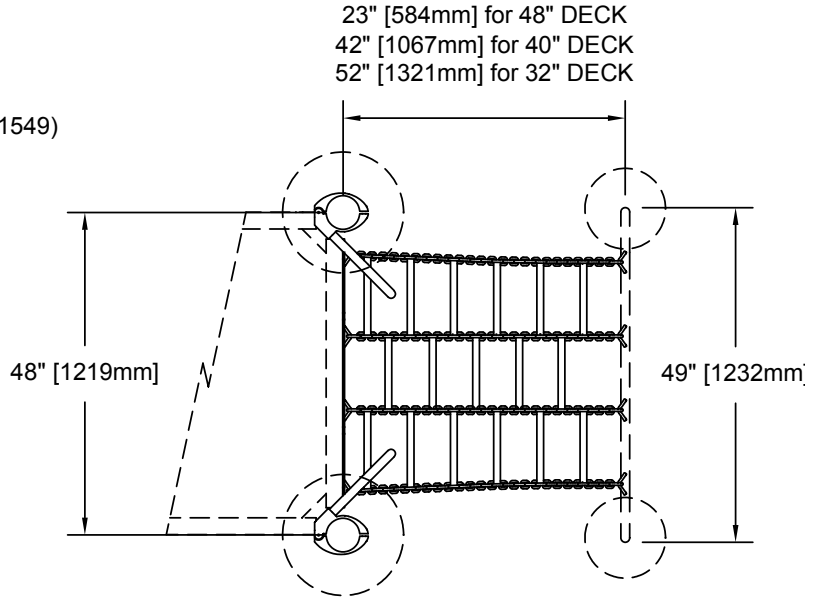

PLAN VIEW

DECK & POSTS (SOLD SEPARATE)

DETAIL 'A'

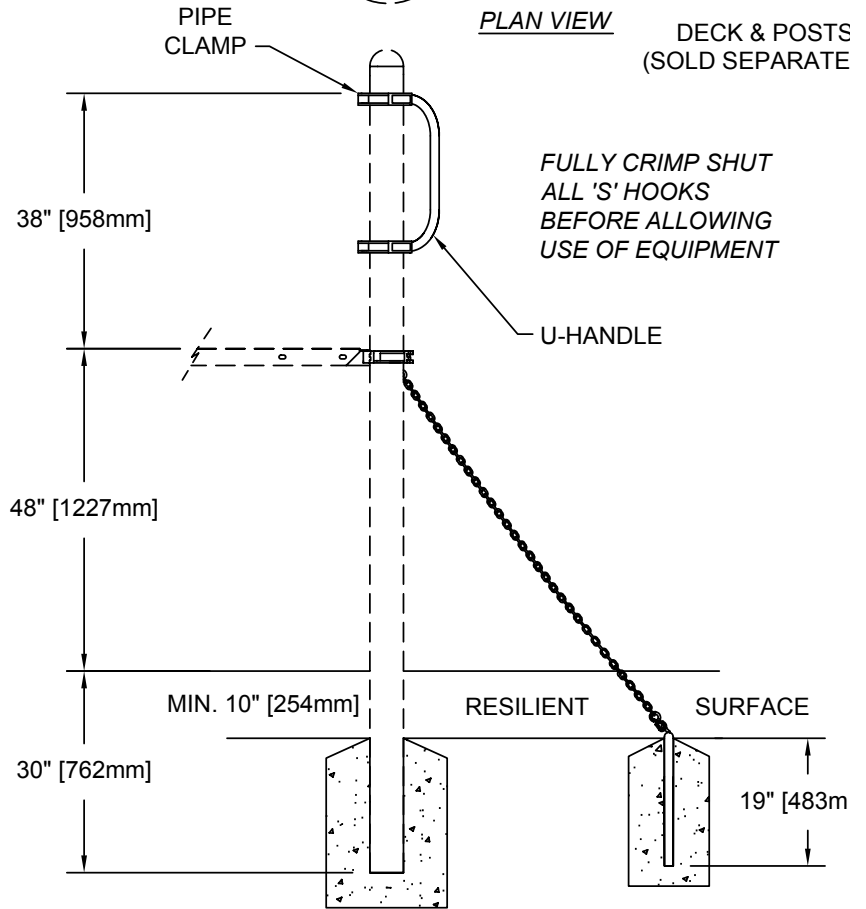
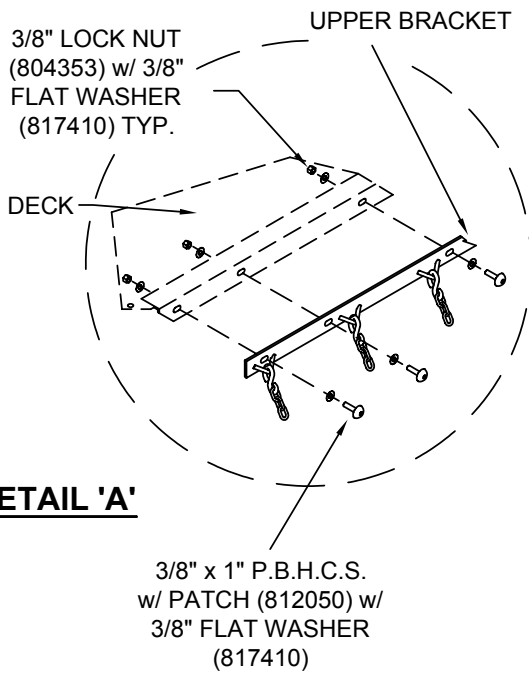

ELEVATION VIEW