

MODEL NO. 60148 Straight Balance Beam MODEL NO. 60150 Straight Balance Beam- Surface Mount

PARTS LIST

DESCRIPTION	60148	60150	PART NUMBER
Straight Balance Beam	1	0	303157
Straight Balance Beam (Surface Mount)	0	1	303182

*Unless Otherwise Specified, All Units of Measure are Each
* Included in Hardware*

Warning: Small parts and hardware items may present a potential choking hazard. Promptly remove all unused parts from play area.

SPECIFICATIONS:

Balance Beam is fabricated from 2"x3" 11-gauge galvanized steel rectangle tubing with 2-3/8" O.D. 10-gauge galvanized tubing legs welded using stainless steel welds for maximum rust resistance. After fabrication, balance beam is coated with a baked-on polyester powder-coat finish. Optional surface mount legs include a welded 12"x12"x1/4" plate (anchoring hardware not included).

All hardware is stainless steel.

Weight: 56 lb. / 25.5 kg

INSTALLATION INSTRUCTIONS:

1. Dig footings at locations as shown in Footing Diagram.
2. Set the Straight balance beam into the dug holes. Plumb, level and brace in position at the proper height as shown.
3. Pour concrete footings within 4" to the top and taper away from support posts to allow water drainage. Allow to cure at least 48 hours before use. Do not allow use until resilient surfacing is installed.
4. Install resilient surfacing material within the *use zone* of play structure in accordance with ASTM specifications F1292 appropriate for the fall height of each structure. Refer to the *Safety Guidelines*.

MAINTENANCE PROCEDURE:

Periodically check hardware for tightness, and tighten as necessary. Always check all parts for breakage or wear, and immediately put equipment out of service until any faulty parts found are repaired or replaced. Check for rust or paint loss and touch-up if necessary with paint. Check welded areas and verify integrity. Check periodically resilient surfacing for appropriate depth and remove extraneous materials that could cause injury, infection, or disease. Maintain detailed installation, inspection, maintenance, and repair records for each public-use playground equipment.

MODEL NO. 60148 Straight Balance Beam MODEL NO. 60150 Straight Balance Beam- Surface Mount

STANDARD IN-GROUND MOUNT (60148)

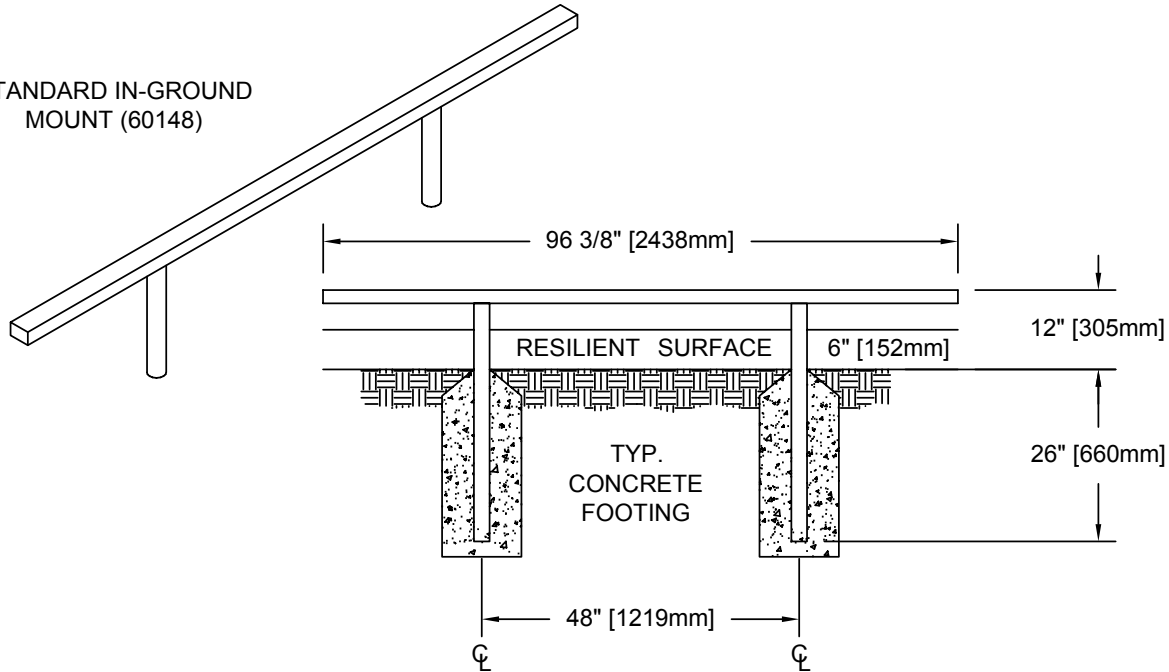

SURFACE MOUNT (60150)

