

MODEL NO. 60149 Balcony Deck

PARTS LIST

DESCRIPTION	No. REQ'D	PART NUMBER
Balcony Deck	1	300531
Pipe Wall	1	302381
Hardware Complete	1	303162
5" O.D. Deck Clamp	2	301989*
1/4" x 3/4" Drive Rivet	2	168449*
3/8" Barrel Nut	2	804804*
3/8" Flat Washer	2	817410*
3/8" (1 1/4" O.D) Flat Washer	14	817424*
3/8" Heavy Hex Nut	2	804200*
3/8" Lock Nut	7	804353*
3/8" x 1" P.B.H.C.S. w/ Patch	7	812050*
3/8" x 1 1/2" P.B.H.C.S. w/ Patch	2	812053*
3/8" x 1 3/4" P.B.H.C.S. w/ Patch	2	812054*

**Unless Otherwise Specified, All Units of Measure are Each
*Included in Hardware**

Warning: Small parts and hardware items may present a potential choking hazard. Promptly remove all unused parts from play area. Any bolt end protruding more than two full threads beyond the face of the nut causes risk of clothing entanglement. Promptly cut-off flush, file smooth, and treat to prevent corrosion.

Note: Peen Tee-Nuts and Flatwashers to match radius of pipe after assembly is complete.

SPECIFICATIONS:

Clamps are cast from a 356 high-strength aluminum alloy with a baked on polyester powder-coated finish. Balcony Deck is fabricated from pre-punched 11-gauge steel sheet. Each deck uses two 11-gauge lower steel flat support-bars that are welded to the deck to increase strength. After welding, entire deck is Plastisol coated with a thickness of 50 to 80 mils on the top of wear surface. Average perforation size is 5/16" diameter after coating. Balcony Pipe Wall is an all stainless steel welded assembly using 1-5/16" O.D. 14-gauge galvanized tubing. Vertical tubes are welded to curved horizontal tubes and the entire assembly is polyester powder-coated after fabrication.

All hardware is stainless steel.

Weight: 94 lb. / 42.7 kg.

INSTALLATION INSTRUCTIONS:

NOTE: A Square, triangle, or hex deck must be already installed and in place on the main structure prior to commencing installation of the Balcony Deck. Such existing deck must be oriented so that its flange with the welded underside supports coincides with the attachment of the Balcony Deck for maximum strength and rigidity.

1. Place Balcony Deck on a flat surface. If necessary, using a 7/16" drill bit, ream out the excess Plastisol coating from the (7) holes located on the flanges, as well as the (4) holes located in the flange of the existing deck, to which it will be attached. Be careful not to expose steel frame.

2. Position the Balcony Deck against the flange of the existing deck and fasten the flanges together using 3/8" x 1" P.B.H.C.S. with Patch, 3/8" (1 1/4" O.D) Flat Washers and 3/8" Lock Nuts as shown in the assembly diagram.

3. Attach two Deck Clamps to the top ends of the Balcony Pipe Wall. Only slightly tighten in the Deck clamps as shown in the assembly diagram (Refer to separate Deck Clamp instructions).

4. Attach Balcony Pipe Wall to Posts using Deck Clamps. Position so that slots in bottom tabs match balcony flange holes while balcony is held level. Only slightly tighten top two Deck Clamps to the Up right Posts. Fasten bottom of Balcony Pipe Wall to flange of Balcony Deck using 3/8" x 1" P.B.H.C.S. with Patch, 3/8" Flat Washers, 3/8" (1 1/4" O.D.) Flat Washers and 3/8" Lock Nuts as shown in the assembly diagram.

MODEL NO. 60149 Balcony Deck

5. When the structure is finished and satisfactory, tighten all fasteners and install Drive Rivets in all Clamps to ensure clamps cannot slide down posts. **It is very important that all Drive Rivets be installed prior to allowing use of the equipment, as clamps are not designed to support substantial weight without them.** Eliminate sharp points and sharp edges (burring) on installed hardware like bolts, nuts, etc. Install resilient surfacing material within the use zone of play structure in accordance with ASTM specifications F1292 appropriate for the fall height of each structure. Refer to the Safety Guidelines.

MAINTENANCE PROCEDURE:

Periodically check hardware for tightness, and tighten as necessary. Always check all parts for breakage or wear, and immediately put equipment out of service until any faulty parts found are repaired or replaced. Check for rust or paint loss and touch-up if necessary with paint. Check welded areas and verify integrity. Check Plastisol-coating for bare spots and touch-up with Plastisol if necessary. Clear any trapped debris from deck perforations. Check periodically resilient surfacing for appropriate depth and remove extraneous materials that could cause injury, infection, or disease. Maintain detailed installation, inspection, maintenance, and repair records for each public-use playground equipment.

MODEL NO. 60149 Balcony Deck

NOTE: IT IS IMPORTANT TO POSITION THE DECK CLAMP SUCH THAT THE DIMENSION BETWEEN VERTICAL RUNG AND UPRIGHT IS LESS THAN 3 1/2".

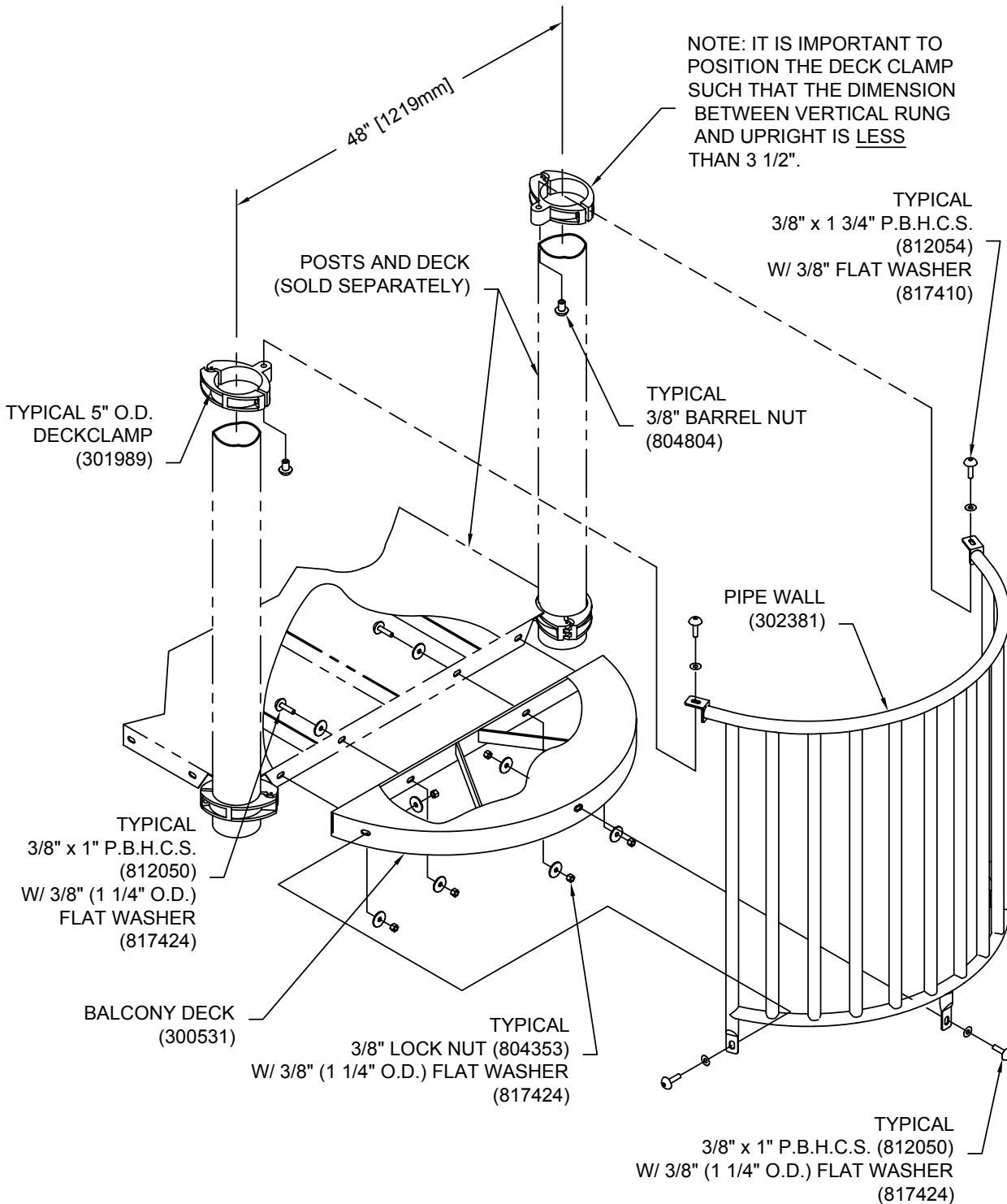

TYPICAL ASSEMBLY