

## MODEL NO. 60159 Flower Maze Panel

### PARTS LIST

DESCRIPTION	No. REQ'D	PART NUMBER
Pre-assembled Flower Maze Panel	1	306627
<b>Hardware Complete</b>	1	306525
5" O.D. Panel Clamp	4	302099*
1/4" x 3/4" Drive Rivet	4	168449*
3/8" Barrel Nut	4	804804*
3/8" Flat Washer	4	817410*
3/8" Heavy Hex Nut	4	804200*
3/8" x 1 1/2" P.B.H.C.S. w/Patch	8	812053*

**Unless Otherwise Specified, All Units of Measure are Each  
\*Included in Hardware**

**Warning: Small parts and hardware items may present a potential choking hazard. Promptly remove all unused parts from play area. Any bolt end protruding more than two full threads beyond the face of the nut causes risk of clothing entanglement. Promptly cut-off flush, file smooth, and treat to prevent corrosion.**

**Note: Peen Tee-Nuts and Flatwashers to match radius of pipe after assembly is complete.**

**Note: Loctite (supplied by others) should be used on any non-patch hardware.**

### SPECIFICATIONS:

Clamps are cast from a 356 high-strength aluminum alloy with a baked on polyester powder-coated finish. Panel is cut from a sheet of high density .850" thick extruded solid polyethylene with color molded in and UV-stabilized.

Primary hardware is stainless steel.

Weight: 57 lbs. / 25 kg.

### INSTALLATION INSTRUCTIONS:

1. Attach Panel Clamps to Pre-assembled Flower Maze Panel using 3/8" x 1 1/2" P.B.H.C.S. w/Patch with 3/8" Flat Washers and Barrel Nuts as shown in the assembly drawing.
2. Fasten Panel Clamps to upright Posts (refer to separate Panel Clamp fastening detail).

**Note:** Panels should be positioned so that the top of each panel is at least 38" above the deck surface. If a conflict exists between a panel clamp and an adjacent component's clamp, adjust the panel upward (Never lower than 38" above deck) without exceeding a maximum gap of 3-1/2" between the lower end of the panel and the top edge of the deck.

**IMPORTANT!** Avoid creating any Gaps between the components, which fall between 3-1/2" and 9". It has been shown that such gaps create entrapment points which can trap a child and cause injury.

3. Plumb the Flower Maze Panel assembly and tighten Panel Clamp fasteners.
4. When the assembly is finished and satisfactory, install Drive Rivets in all clamps to ensure clamps cannot slide down posts. See Panel Clamp sub-assembly sheet. **It is very important that all Drive Rivets be installed prior to allowing use of the equipment, as clamps are not designed to support substantial weight without them.** Eliminate sharp points and sharp edges (burring) on installed hardware like bolts, nuts, etc. Install resilient surfacing material within the use zone of play structure in accordance with ASTM specifications F1292 appropriated for the fall height of each structure. Refer to the Safety Guidelines.

## MODEL NO. 60159 Flower Maze Panel

### **MAINTENANCE PROCEDURE:**

Periodically check hardware for tightness, and tighten as necessary. Always check all parts for breakage or wear, and immediately put equipment out of service until any faulty parts found are repaired or replaced. Check for rust, paint peeling and touch-up if necessary with paint. Check for welded areas and verify integrity. Check for cracks, gouges or breakage on plastic, check for integrity of the plastic, keep plastic clean of any extraneous substance, verify that any deformation does not create entrapment as specified on ASTM F1487-95 section 6. Check periodically resilient surfacing for appropriate depth and remove extraneous materials that could cause injury, infection, or disease. Maintain detailed installation, inspection, maintenance, and repair records for each public-use playground equipment.

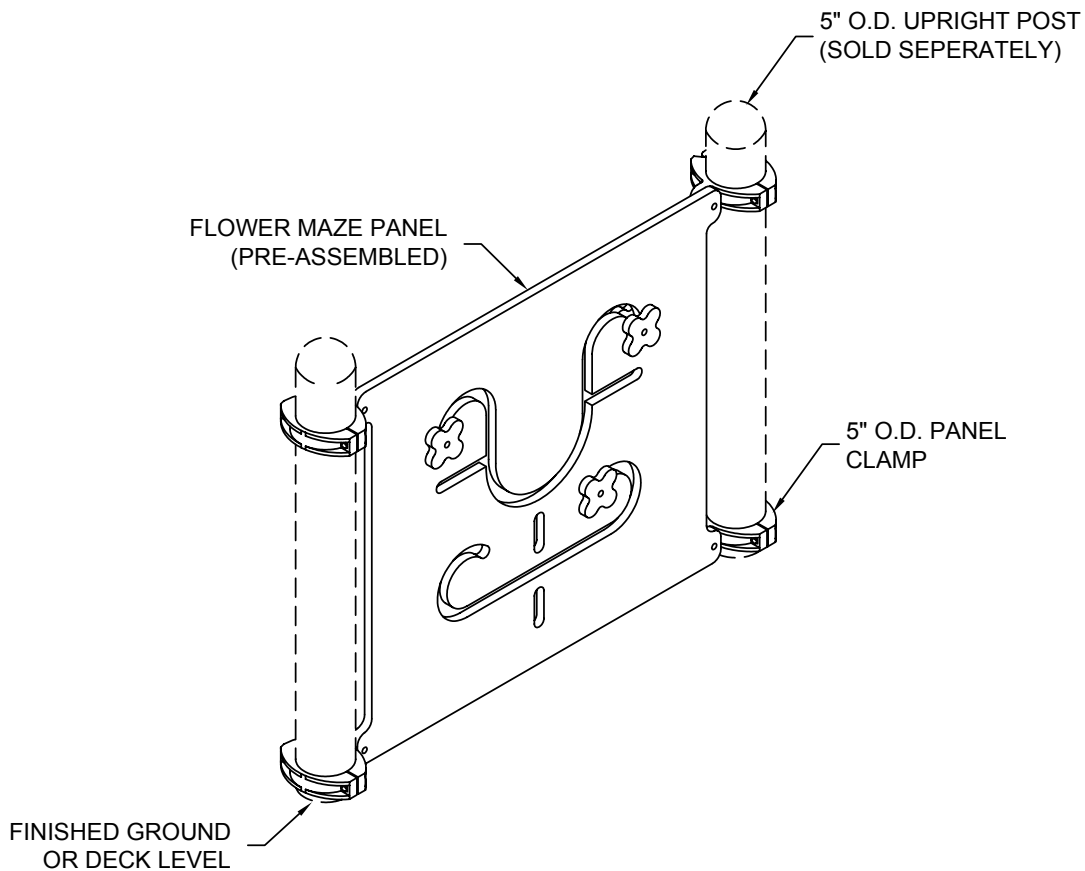

FINISHED ASSEMBLY

## MODEL NO. 60159 Flower Maze Panel

**NOTE:**

TOP EDGE OF PANEL MUST BE 38" [965mm] OR GREATER ABOVE ELEVATED PLATFORM SURFACE FOR USE BY 5-12 YEAR OLDS.

TOP EDGE OF PANEL MUST BE 29" [736mm] OR GREATER ABOVE ELEVATED PLATFORM SURFACE FOR USE BY 2-5 YEAR OLDS.

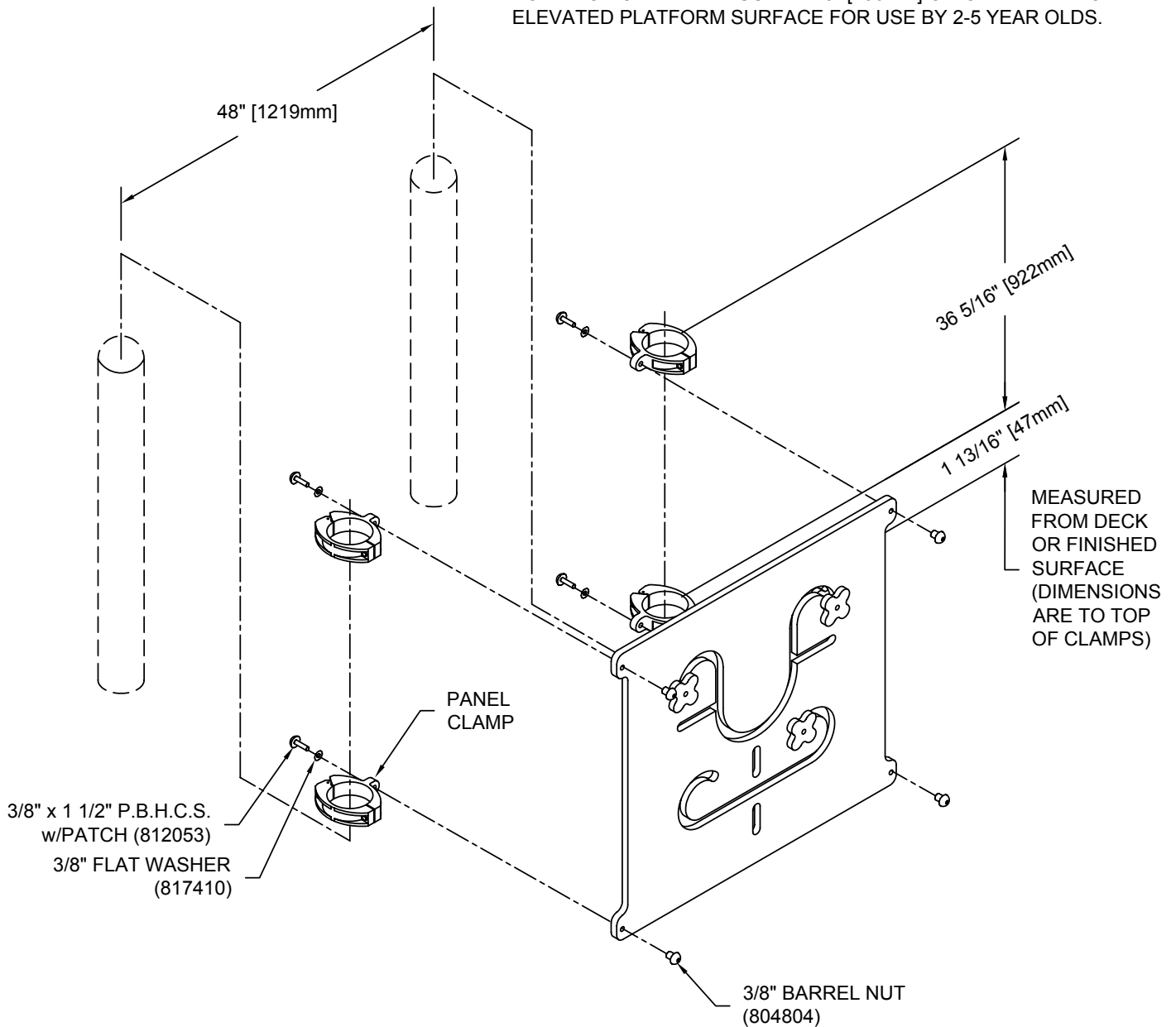

### FLOWER MAZE PANEL ASSEMBLY